

# Installation Guide

*For Anchor Bracket*  
**62-30000**



**SLEIPNER AS**

P.O. Box 519

N-1612 Fredrikstad

Norway

[www.sleipnergroun.com](http://www.sleipnergroun.com)

**DOCUMENT ID: 6884**

**REVISION: 5**

**DATE: 2022**

**LANGUAGE: EN**

**MI**

# Contents

## Installation Manual

Responsibility of the installer.....	3
Anchor Bracket Installation .....	4
<b>Service and Support.....</b>	<b>5</b>
<b>Product Spare Parts and Additional Resources.....</b>	<b>5</b>
<b>Warranty Statement.....</b>	<b>5</b>

## Products

62-30000 - Fjær for vipperulle vinsj



Sleipner Motor AS  
P.O. Box 519, Arne Svendsensgt. 6-8  
N-1612 Fredrikstad, Norway

MC\_0020

**Failure to follow the considerations and precautions can cause serious injury, damage and will render all warranties given by Sleipner Motor as VOID.**

MC\_0411

## **Responsibility of the Installer**

MC\_0038

The installer must read this document to ensure necessary familiarity with the product before installation.

Instructions in this document cannot be guaranteed to comply with all international and national regulations. It is the responsibility of the installer to follow all applicable international and national regulations when installing Sleipner products.

The recommendations given in this document are guidelines ONLY, and Sleipner strongly recommends that advice is obtained from a person familiar with the particular vessel and applicable regulations.

This document contains general installation instructions intended to support experienced installers. If you are not skilled in this type of work, please contact professional installers for assistance.

If required by local regulation, electrical work must be done by a licensed professional.

Appropriate health and safety procedures must be followed during installation.

Faulty installation of Sleipner products will render all warranties given by Sleipner Motor AS.

**! Please refer to the graphic for special considerations relating to your model !**

1. Disassemble the Anchor bracket in the defined configuration.
2. Assemble the Anchor bracket in the defined configuration with the new spring.
3. Fasten the end pins to finish the anchor bracket assembly.
4. Example of the anchor bracket assembly in anchor down and anchor up.

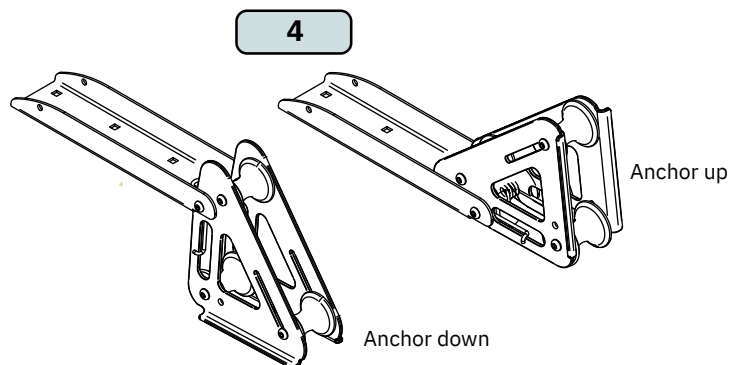
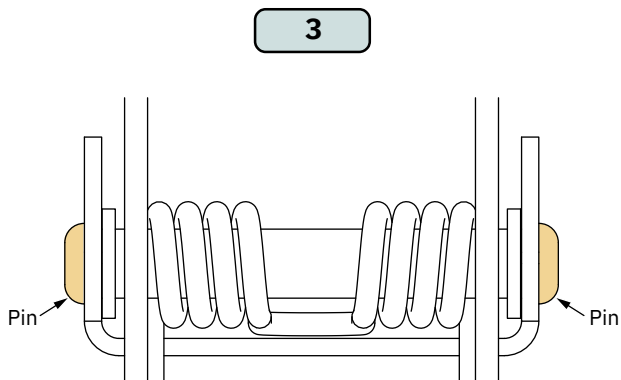
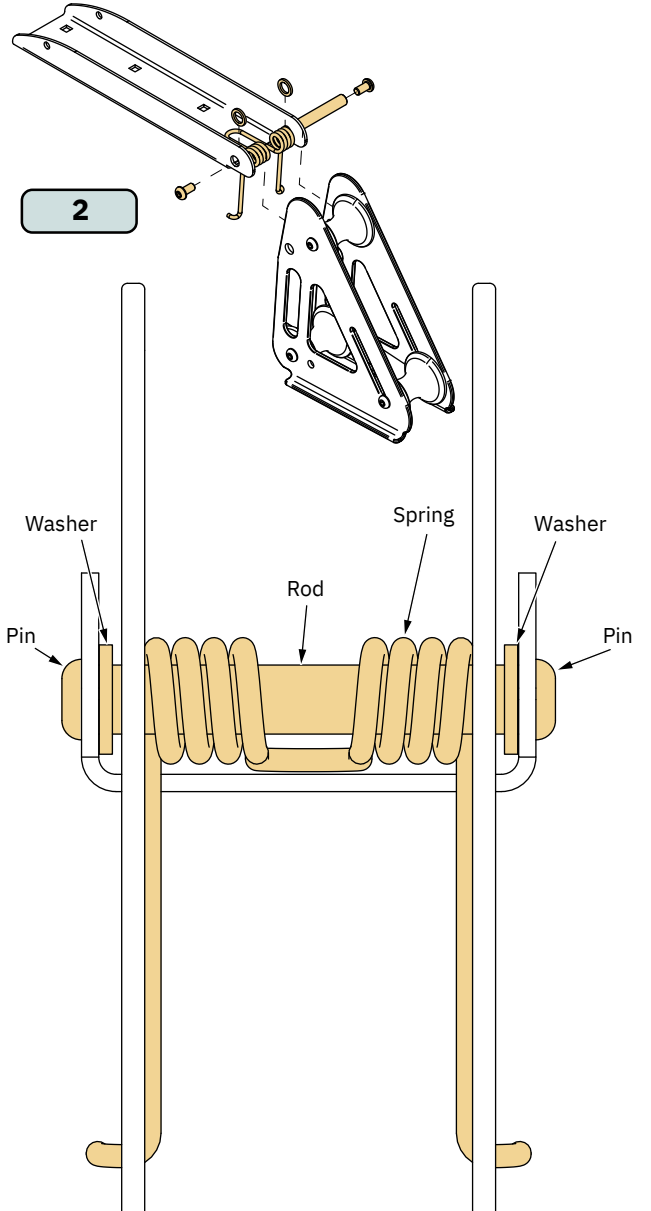
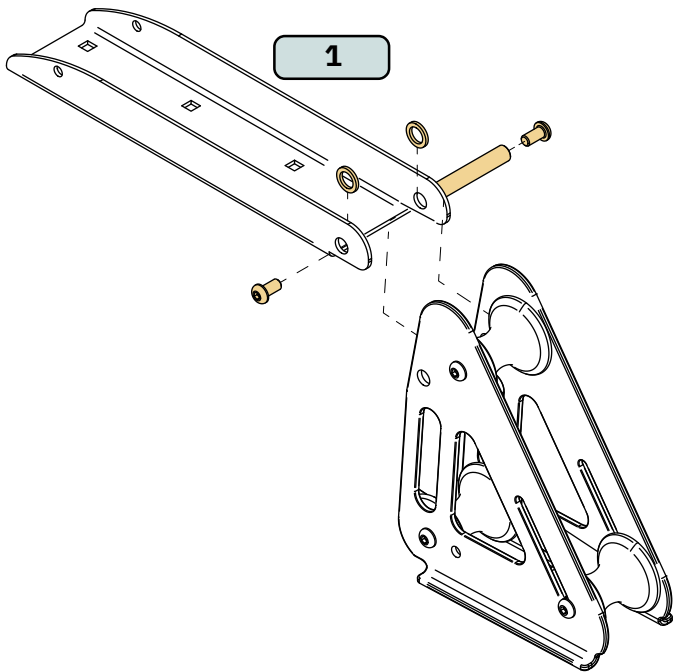

**Find your local professional dealer from our certified worldwide network for expert service and support. visit our website [www.sleipnergrou.com/support](http://www.sleipnergrou.com/support)**

### Product Spare Parts and Additional Resources

**For additional supporting documentation, we advise you to visit our website [www.sleipnergrou.com](http://www.sleipnergrou.com) and find your Sleipner product.**

### Warranty statement

1. Sleipner Motor AS (The “Warrantor”) warrants that the equipment (parts, materials, and embedded software of products) manufactured by the Warrantor is free from defects in workmanship and materials for purpose for which the equipment is intended and under normal use and maintenance service (the “Warranty”).
2. This Warranty is in effect for two years (Leisure Use) or one year (Commercial and other Non-leisure Use) from the date of delivery/purchase by the end user, with the following exceptions;
  - (a) For demonstration vessels, or vessels kept on the water, the dealer is considered as the end user from 6 months after their launch of the vessel;
  - (b) The warranty period starts no later than 18 months after the first launch of the vessel.
 Please note that the boat manufacturer and dealer must pay particular attention to correct maintenance and service both by the products manuals as well as general good practice for the location the boat is kept in the period the boat is in their care. In cases where the 6 and 18 months grace periods for boat builders and dealers are passed, it is possible to obtain a full warranty upon inspection and approval of the warrantor or such representative.
3. Certain parts, classified as wearable or service parts, are not covered by the warranty. A failure to follow the required maintenance and service work as described in the product manual render all warranty on parts or components directly or indirectly affected by this void. Please also note that for some parts, time is also a factor separately from actual operational hours.
4. This Warranty is transferable and covers the equipment for the specified warranty period.
5. The warranty does not apply to defects or damages caused by faulty installation or hook-up, abuse or misuse of the equipment including exposure to excessive heat, salt or fresh water spray, or water immersion except for equipment specifically designed as waterproof.
6. In case the equipment seems to be defective, the warranty holder (the “Claimant”) must do the following to make a claim:
  - (a) Contact the dealer or service centre where the equipment was purchased and make the claim. Alternatively, the Claimant can make the claim to a dealer or service centre found at [www.sleipnergrou.com](http://www.sleipnergrou.com). The Claimant must present a detailed written statement of the nature and circumstances of the defect, to the best of the Claimant’s knowledge, including product identification and serial nbr., the date and place of purchase and the name and address of the installer. Proof of purchase date should be included with the claim, to verify that the warranty period has not expired;
  - (b) Make the equipment available for troubleshooting and repair, with direct and workable access, including dismantling of furnishings or similar, if any, either at the premises of the Warrantor or an authorised service representative approved by the Warrantor. Equipment can only be returned to the Warrantor or an authorised service representative for repair following a pre-approval by the Warrantor’s Help Desk and if so, with the Return Authorisation Number visible postage/shipping prepaid and at the expense of the Claimant.
7. Examination and handling of the warranty claim:
  - (a) If upon the Warrantor’s or authorised service Representative’s examination, the defect is determined to result from defective material or workmanship in the warranty period, the equipment will be repaired or replaced at the Warrantor’s option without charge, and returned to the Purchaser at the Warrantor’s expense. If, on the other hand, the claim is determined to result from circumstances such as described in section 4 above or a result of wear and tear exceeding that for which the equipment is intended (e.g. commercial use of equipment intended for leisure use), the costs for the troubleshooting and repair shall be borne by the Claimant;
  - (b) No refund of the purchase price will be granted to the Claimant, unless the Warrantor is unable to remedy the defect after having a reasonable number of opportunities to do so. In the event that attempts to remedy the defect have failed, the Claimant may claim a refund of the purchase price, provided that the Claimant submits a statement in writing from a professional boating equipment supplier that the installation instructions of the Installation and Operation Manual have been complied with and that the defect remains.
8. Warranty service shall be performed only by the Warrantor, or an authorised service representative, and any attempt to remedy the defect by anyone else shall render this warranty void.
9. No other warranty is given beyond those described above, implied or otherwise, including any implied warranty of merchantability, fitness for a particular purpose other than the purpose for which the equipment is intended, and any other obligations on the part of the Warrantor or its employees and representatives.
10. There shall be no responsibility or liability whatsoever on the part of the Warrantor or its employees and representatives based on this Warranty for injury to any person or persons, or damage to property, loss of income or profit, or any other incidental, consequential or resulting damage or cost claimed to have been incurred through the use or sale of the equipment, including any possible failure or malfunction of the equipment or damages arising from collision with other vessels or objects.
11. This warranty gives you specific legal rights, and you may also have other rights which vary from country to country.

### Patents

At Sleipner we continually reinvest to develop and offer the latest technology in marine advancements. To see the many unique designs we have patented visit our website [www.sleipnergrou.com/patents](http://www.sleipnergrou.com/patents)

© **Sleipner Group**, All rights reserved  
The information given in the document  
was right at the time it was published.  
However, Sleipner Group cannot  
accept liability for any inaccuracies or  
omissions it may contain. Continuous  
product improvement may change the  
product specifications without notice.  
Therefore, Sleipner Group cannot accept  
liability for any possible differences  
between product and document.

**Register your product and learn more  
at [www.sleipnergroun.com](http://www.sleipnergroun.com)**



**SLEIPNER AS**

P.O. Box 519

N-1612 Fredrikstad

Norway

[www.sleipnergroun.com](http://www.sleipnergroun.com)

Made in Norway

