

Keep this
manual onboard!



User Manual

*Including Installation For
Hydraulic Proportional Controller
PHC-3*



DOCUMENT ID: 5267

REVISION: 26

DATE: 2025

LANGUAGE: EN



Contents

Warnings and Safety	2
User Manual	
Product Description	3
Panel Layout & Functions	3
LED Status	3
Menu	4
Menu - Active Faults	5
Menu - Device Info	5
Menu - Parameters	6
Menu - Diagnostic	16
Menu - Manual Operation	20
S-Link Fault Codes	22
Fault code navigator	22
Installation Guide	
Responsibility of the Installer	23
Product Specifications	24
PHC-3 Dimensions	24
73830 Thruster Control Cabinet Dimensions	24
PHC-3 Installation	25
S-Link System Description	26
List of Installed S-Link Devices	27
Sleipner Group Waste Disposal and Recycling Guide	28
Service and Support	29
Product Spare Parts and Additional Resources	29
Warranty Statement	29
Patents	29

Warnings and Safety

MC_0800

It is essential to follow all instructions within this document to avoid potential personal injury, death, or damage to existing products in the vessel, the vessel's hull integrity, and including this product during installation or operation. Failure to follow instructions within this document will render all warranties given by Sleipner Motor as VOID.

Warnings and situations requiring extra caution are outlined in the documentation. Take extra consideration when warnings are outlined.



WARNING
Indicate a potentially hazardous situation that, if not avoided, could result in death or severe injury.



CAUTION
Indicates a potentially hazardous situation that could result in minor or moderate injury or critical damage to vessel integrity if not avoided.

MC_0020

Hydraulic controller for S-Link™ thruster- and stabilizer systems

- S-Link™ CAN-bus communication
- IP65 water ingress rated enclosure
- Offering system status and control, both local and remote
- Intelligent load control of generators
- Plug & Play cables, waterproof and compact connectors
- Preprogrammed and tested for system deliveries

The PHC-3 hydraulic control is normally fitted on Hydraulic Systems delivered by Sleipner. PHC-3 can also be delivered as a standalone product or pre-installed in a junction box with terminal blocks. The junction box solution 73830 Thruster Control Cabinet is only compatible with hydraulic thruster systems.



Hydraulic System



PHC-3 Standalone

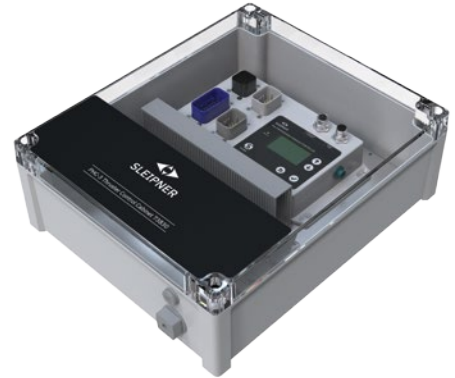

73830 Thruster Control Cabinet

MG_0642

Product Layout & Functions

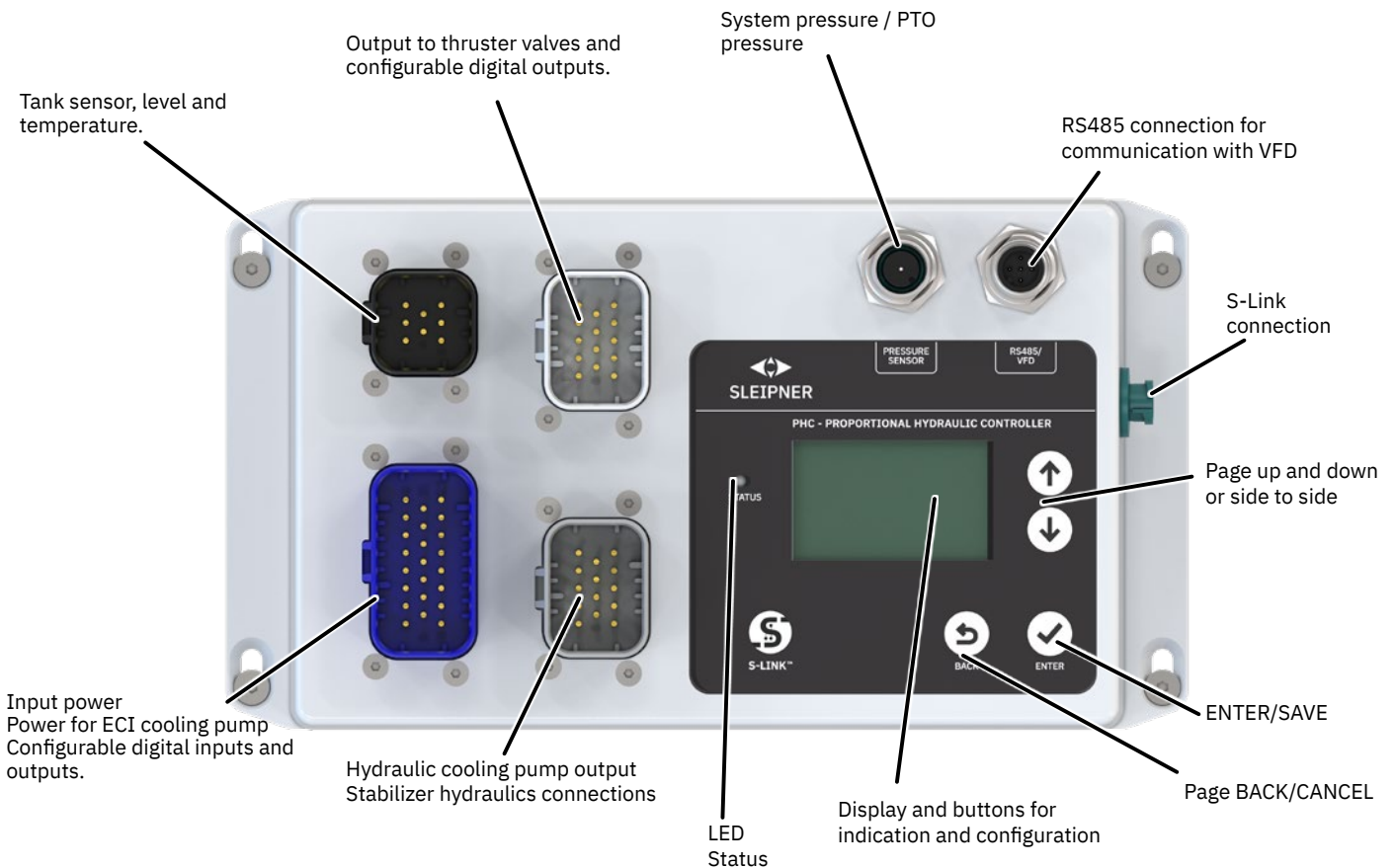

LED Status

Continuous GREEN	Flashing GREEN
PHC-3 is powered and has S-link communication and there are no faults	No S-link communication
Continuous RED	
PHC-3 have a fault, enter ACTIVE FAULTS menu for details.	

1. Main Menu

Use ↑↓arrow buttons to switch between these views:

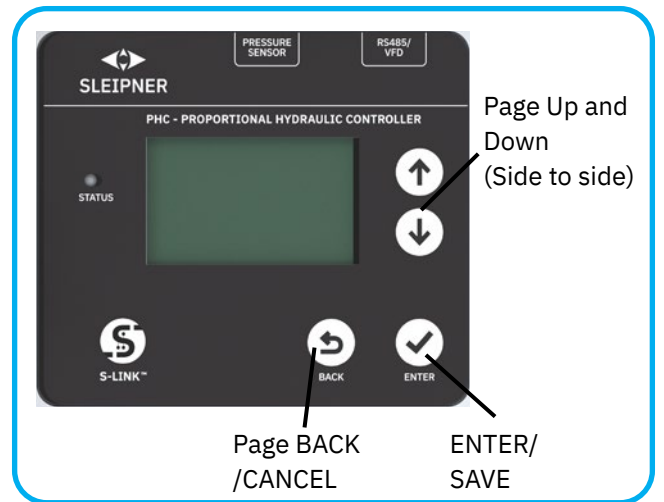
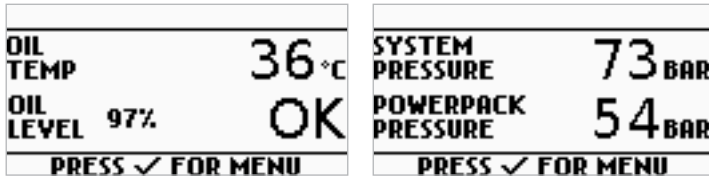

1.2 MAIN SCREENS and SYMBOLS

1.2.1 Alarm Bell

▲(alarm bell) is flashing in upper left corner when any fault has been triggered. When a fault is triggered the display will jump to the FAULTS menu. Pushing the ↩(back) button will bring you back to the previous menu.

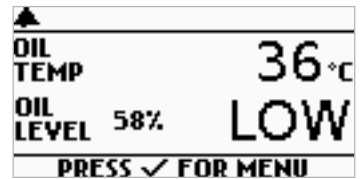

1.2.2 VFD

A symbol (AC) power-pack AC motor is showing status of the VFD at the top. The field will be blank when VFD is ready and not active. VFD must be configured in parameter 1001 for this symbol to show.

- (AC) VFD is the active power source but motor is not running.
- (AC) OFF VFD is not connected or not powered.
- (AC) RUN VFD is running.
- (AC) LOC VFD is in local mode.
- (AC) ERR VFD is not ready or any fault.
- (AC) X VFD is waiting for run enable signal from power management system.

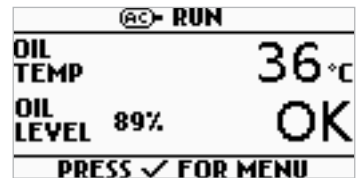

1.2.3 OIL TEMP

Oil temp and oil level screen will not show if tank monitor sensor type parameter 0201 is deactivated.

Tank monitor sensor type set to analogue temp.

Flashing text “COOLING” when cooling pump is running. Cooling starts at 45°C (113°F) and stops at 40°C (104°F).

Tank monitor sensor type set to NC temp (temp switch).

Oil temp is indicated with NORMAL or HIGH. Flashing text “COOLING” when cooling pump is running.

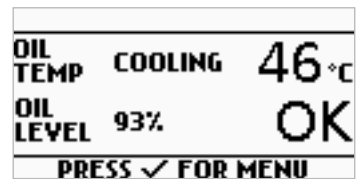
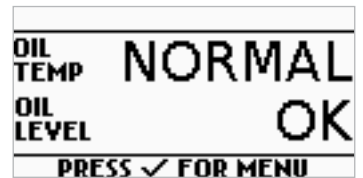

1.2.4 OIL LEVEL

Oil level is indicated with OK or LOW. If oil level sensor is analogue then oil level is also indicated with level in percent (i.e. 97%).

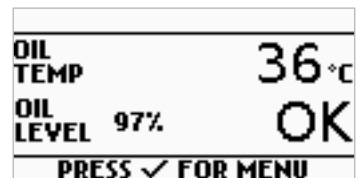

1.2.5 PRESSURE

Shows system pressure and power-pack pressure in bar.

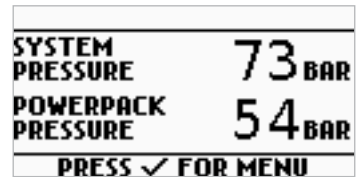



2. Menu - ACTIVE FAULTS

MENU
ACTIVE FAULTS
DEVICE INFO
PARAMETERS
DIAGNOSTIC
1/5

2.1 FAULTS

 flashing in upper left corner when any fault has been triggered.
Go to ACTIVE FAULTS menu for fault details.

	<p>Indicates that there are no active faults.</p>
	<p>Each fault is shown with a fault code number (i.e. 10501.0.16) followed by code name (OIL TEMP) and at the second line a fault condition (SHORT CIRCUIT).</p> <p>Pressing ✓ENTER will reset all faults. See PHC-3 Fault Codes chapter for fault code descriptions.</p>

3. Menu - Device Info

MENU
ACTIVE FAULTS
DEVICE INFO
PARAMETERS
DIAGNOSTIC
2/5

3.1 DEVICE INFO - SERIAL NUMBER and FIRMWARE



Displays PHC-3 serial number and firmware version.

DEVICE INFO
SERIAL NUMBER
301848
FIRMWARE
VERSION 1.014
1/3

3.2 CHANGED PARAMETERS

Enter to see changed parameters.
The PHC-3 controller parameters are setup specifically for each system at the factory.
Changed parameters are parameters that do not match setup from factory.

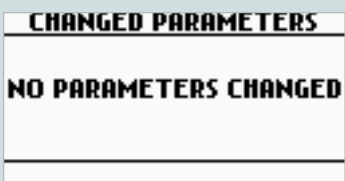
DEVICE INFO
FIRMWARE
VERSION 1.014
CHANGED PARAMETERS
✓=ENTER 3/3

	<p>If no parameters are changed.</p>
	<ul style="list-style-type: none"> - If one or more parameters is changed. - A list of all parameters that has been changed are viewed. - The list can be scrolled by using the  arrow buttons. - In the down right corner, you can see how many parameters that has been changed and in this example there are 5 changed parameters. - Editing parameters cannot be done here. - To restore <u>all</u> parameters to default values as setup from factory, push and hold the enter button for 3 seconds. When screen shows DEVICE INFO menu, parameters are restored.

4. Menu - PARAMETERS

For edit parameter press ✓Enter.

While editing press ✓Enter to save new value and press ↩ Back for cancel editing.

MENU
ACTIVE FAULTS
DEVICE INFO
PARAMETERS
DIAGNOSTIC
3/5

4.1 PARAMETERS - 01 DEVICE SETTINGS

No.	Name/Value	Description
		<div style="display: flex; justify-content: space-around;"> <div style="border: 1px solid black; padding: 2px;"> <p style="text-align: center; margin: 0;">PARAMETERS</p> <p style="margin: 0;">01-DEVICE SETTINGS</p> <p style="margin: 0;">02-TANK MONITOR</p> <p style="margin: 0;">03-COOLING PUMP</p> <p style="margin: 0;">05-DIGITAL OUTPUTS</p> <p style="text-align: right; margin: 0;">1/8</p> </div> <div style="border: 1px solid black; padding: 2px;"> <p style="text-align: center; margin: 0;">DEVICE SETTINGS</p> <p style="margin: 0;">0101-INSTANCE</p> <p style="margin: 0; text-align: center;">NONE</p> <p style="margin: 0;">0102-THRUSTER CONFIG</p> <p style="margin: 0;">0103-PUMP2 OUTPUT</p> <p style="margin: 0;">✓=EDIT</p> <p style="text-align: right; margin: 0;">1/4</p> </div> </div>
0101	INSTANCE	Defines PHC-3 controller instance.
	NONE (default)	Use this for mono hull boats with one PHC-3 controller
	PORT	Catamaran use, with PHC-3 at PORT side
	STARBOARD	Catamaran use, with PHC-3 at STARBOARD side
0102	THRUSTER CONFIG	Defines relationship between control signals and thruster valve outputs. If thruster is operated in wrong direction, use parameter 2002 to swap bow valve output and parameter 2102 to swap stern valve output.
	BOW/STERN (default)	Bow control signal operates bow valve. Stern control signal operates stern valve.
	BOW/BOW	Bow control signal operates bow and stern valve as one thruster.
	STERN/STERN	Stern control signal operates bow and stern valve as one thruster.
0103	PUMP2 OUTPUT	Defines how PUMP2 shutdown valve are operated
	DEACTIVATED	PUMP2 output function is deactivated and output is 0V.
	ALWAYS ON	PUMP2 output is always on (activated) and pressure from PUMP2 is shutdown.
	AUTOMATIC (default)	The system will automatically control load sharing between two PTO pumps by shutting down the second PTO pump (PUMP2 OUTPUT) when not needed (two PTO pumps/control valves required) to reduce heat generation in the system and save fuel/energy. When any thruster is running, both PTO pumps will be active to ensure good performance. When a stabilizer system is active, PUMP2 OUTPUT will be +12/24V. Second PTO pump is then shutdown to save power. If stabilizers are active and the stabilizer pressure drops 30% lower than set-point, the system will change PUMP2 OUTPUT to 0V to wakeup second pump for 15 minutes to increase the flow capacity and maintain required pressure. After 15 minutes PUMP2 OUTPUT will be reverted to +12/24V (shutdown) unless the stabilizer pressure is still 30% lower than set-point. When stabilizer system is turned off, all pumps will be activated (0V).
0104	SYSTEM PRESSURE	Defines system pressure sensor type.
	INPUT DEACTIVATED	No system pressure sensor connected
	ANALOG INPUT (default)	0-400bar pressure sensor (4-20mA)
	SWITCH INPUT	Standby pressure switch

4.2 PARAMETERS - 02 TANK MONITOR

		PARAMETERS	TANK MONITOR
		01-DEVICE SETTINGS	0201-SENSOR TYPE
		02-TANK MONITOR	AN-LEVEL/AN-TEMP
		03-COOLING PUMP	0202-OIL ALARM LEVEL
		05-DIGITAL OUTPUTS	0203-TANK HEIGHT
		2/8	✓=EDIT 1/4
No.	Name/Value	Description	
0201	SENSOR TYPE	Defines the oil tank level and temperature sensor type	
	DEACTIVATED	No tank sensor connected	
	NC-LEVEL/NC-TEMP	Normally Closed level switch and Normally Closed temp switch	
	NO-LEVEL/AN-TEMP	Normally Open level switch and analog temp sensor (NTC 10K), part no.: 10 2540 & 10 2542	
	AN-LEVEL/AN-TEMP (default)	Analog level sensor (0-180ohm) and analog temp sensor (NTC 10K), part no.: 10 2543	
0202	OIL ALARM LEVEL	Sets the oil alarm level	
	0-100% (default 65%)	Alarm level in steps of 5%	
0203	TANK HEIGHT	The height of the oil tank. If tank don't have flat bottom then measure from center of the tank. This parameter is important for correct alarm level.	
	300mm – 15000mm (default 350mm)	Height in steps of 1mm	
0204	OIL LEVEL 100%	Defines the 100% oil level from the bottom of the tank. If tank doesn't have flat bottom then measure from center of the tank. This parameter is important for correct alarm level.	
	150mm – 15000mm (default 270mm)	Level in steps of 1mm	

4.3 PARAMETERS - 03 COOLING PUMP

		PARAMETERS	COOLING PUMP
		01-DEVICE SETTINGS 02-TANK MONITOR 03-COOLING PUMP 05-DIGITAL OUTPUTS 3/8	0301-PUMP TYPE D-OUT 4 BLUE HARNESS 0302-PUMP MODE 0303-ECI PUMP SPEED ✓=EDIT 1/7
No.	Name/Value	Description	
0301	PUMP TYPE	Defines the cooling pump type	
	NONE	No cooling pump is connected	
	D-OUT 4 BLUE HARNESS (default)	Cooling pump is connected to Digital Output 4 on the blue harness. See also DIGITAL OUTPUTS parameter for more information	
	HYDRAULIC GREY HARNESS	Hydraulic cooling pump on the grey harness	
	ELECTRIC ECI	Electric ECI cooling pump	
	CC MODULE	Cooling Control Module The CC Module is an external enclosed unit that controls one AC pump and one DC pump. The AC pump is prioritized when AC power-pack is running, in other operating states the 24V DC pump is prioritized. If one pump fails, the system will try to use the second pump.	
0302	PUMP MODE	Defines how the cooling pump are operated	
	DEACTIVATED	Cooling pump will not be activated (used if cooling is provided by external system)	
	ALWAYS ON	Cooling pump is activated and always running (5 seconds delay before start of hydraulic cooling pump when starting power-pack)	
	TEMP CONTROLLED (default)	Cooling pump is activated at 45°C (113°F) and deactivated at 40°C (104°F) if system use temperature sensor. If system use temperature switches, cooling is controlled by switch state.	
0303	ECI PUMP SPEED	Sets ELECTRIC ECI pump speed if selected as PUMP TYPE	
	800rpm – 1600rpm (default 1400rpm)	Speed in steps of 100rpm.	
0304	POWER SAVE	Cooling pump power save function.	
	DEACTIVATED	POWER SAVE is deactivated and cooling pump will act accordingly to PUMP MODE setting (parameter 0302).	
	ACTIVATED (default)	Cooling pump will go into power save mode and stop cooling pump and set selected output to 0V when there is no system pressure and power-pack is inactive (VFD not running) for more than 10 seconds. When power save mode is not triggered the cooling pump will act accordingly to PUMP MODE setting (parameter 0302).	
0305	TRIM FUNCTION	Cooling pump trim function. Cooling pump trim function is to run the cooling pump for 30 seconds on regular basis to reduce the risk of corrosion, growing and sticking seal. (NB! For hydraulic cooling pump to rotate there must be hydraulic pressure applied). Apply for all cooling pump types.	
	DEACTIVATED	Cooling pump trim function is deactivated	
	ACTIVATED (default)	Cooling pump starts: <ul style="list-style-type: none"> • 60 seconds after PHC-3 has been powered • every time system-pressure or stabilizer-pressure is applied • every 6 days if PHC-3 has continuous power 	
0380	ECI FIRMWARE	Shows the ECI cooling pump firmware version. This is read only	
	VERSION 1.5.0	The Version number is requested from the ECI pump	
	NA	Not Available, ECI pump is not connected	
0381	CCM FIRMWARE	Shows the CCM cooling module firmware version. This is read only	
	VERSION 1.00	Version number is requested from the CC Module	
	NA	Not Available, CC Module is not connected	

4.4 PARAMETERS - 05 DIGITAL OUTPUTS

		PARAMETERS	DIGITAL OUTPUTS
		01-DEVICE SETTINGS 02-TANK MONITOR 03-COOLING PUMP 05-DIGITAL OUTPUTS 4/8	0501-D-OUTPUT 1 0 NOT IN USE 0502-D-OUTPUT 2 0503-D-OUTPUT 3 ✓=EDIT 1/6
No.	Name/Value	Description	
0501 0502 0503 0504 0505 0506	D-OUTPUT 1 D-OUTPUT 2 D-OUTPUT 3 D-OUTPUT 4 D-OUTPUT 5 D-OUTPUT 6	Sets a function for the selected digital output. Any function can be set to any digital output. If the number in front of the value/function name is negative (like -1 BOW CROSSOVER) then the output is inverted. Digital output feeds +24V to the output and max load is 2.0A per output.	
	0-NOT IN USE (default)	Output is not in use and set to 0V	
	-1/1-BOW CROSSOVER	Output is activated when input thrust from bow joystick is more than 5%. Remember to set RAMP DECREASE time to preferred 3000ms at parameter 2005. This function is automatically set to D-OUTPUT 1 when parameter 2007 is set to DO-1 BOW CROSSOVER.	
	-2/2-STERN CROSSOVER	Output is activated when input thrust from stern joystick is more than 5%. Remember to set RAMP DECREASE time to preferred 3000ms at parameter 2105. This function is automatically set to D-OUTPUT 2 when parameter 2107 is set to DO-2 STERN CROSSOVER.	
	-3/3-COOLING PUMP	Output is activated according to parameter 0302 PUMP MODE This function is automatically set to D-OUTPUT 4 when parameter 0301 is set to D-OUT 4 BLUE HARNESS.	
	-4/4- BOW THRUST ACTIVE	Output is activated when bow thruster is running.	
	-5/5-STERN THRUST ACTIVE	Output is activated when stern thruster is running.	
	-6/6-ANY THRUST ACTIVE	Output is activated when bow or stern thruster is running.	
	-7/7-THRUSTER ENABLED	Output is activated when any joystick panel is ON. This requires PHC-3 FW V1.009 and PJC222/221 FW V2.024 or newer	
	-8/8-STAB.PTO P.UNLOAD	Output is activated when stabilizer is running from PTO pressure. This function is used on nonstandard option systems (10 4450B-W-X02). Enabling this function also require setting of parameter 1011-PTO ENGINE INSTANCE.	
	-9/9-LOW OIL LEVEL ALARM	Output is active when there is a low oil level fault	
	-10/10-BOW CROSSOVER WITH BREAK	10-NO Valve: Output is Low (0V) when PVG feed is ON and input thrust from bow joystick is less than 5%. Rest of the time the output is High (+24V). -10-NC Valve: Output is High (+24V) when PVG feed is ON and input thrust from bow joystick is less than 5%. Rest of the time the output is Low (0V). The purpose of this output function is to prevent the propeller to rotate while running the boat in high speed and reduce the noise. Remember to set RAMP DECREASE time to preferred 3000ms at parameter 2005.	
	-11/11-STERN CROSSOVER WITH BREAK	11-NO Valve: Output is Low (0V) when PVG feed is ON and input thrust from bow joystick is less than 5%. Rest of the time the output is High (+24V). -11-NC Valve: Output is High (+24V) when PVG feed is ON and input thrust from bow joystick is less than 5%. Rest of the time the output is Low (0V). The purpose of this output function is to prevent the propeller to rotate while running the boat in high speed and reduce the noise. Remember to set RAMP DECREASE time to preferred 3000ms at parameter 2105.	
	-12/12 – ACTIVE FAULT	Output is activated when PHC-3 has any active fault	
	-13/13 – SYSTEM PRESSURE AVAILABLE	Output is activated when system pressure is available. Parameter 0104 SYSTEM PRESSURE, sensor must be selected. -ANALOG INPUT: Pressure available when system pressure is higher than parameter 1009 PTO PUMP PRESSURE DETECT LEVEL -SWITCH INPUT: Pressure available when standby pressure switch detects pressure. -D-OUTPUT function STAB.PTO P.UNLOAD used on any digital outputs: Pressure available when motor speed is >500RPM	

4.5 PARAMETERS - 06 DIGITAL INPUTS

PARAMETERS 02-TANK MONITOR 03-COOLING PUMP 05-DIGITAL OUTPUTS 06-DIGITAL INPUTS 5/8	DIGITAL INPUTS 0601-D-INPUT 1 0 NOT IN USE 0602-D-INPUT 2 0604-D-INPUT 4 ✓=EDIT 1/3
--	--

No.	Name/Value	Description
0601 0602 0604	D-INPUT 1 D-INPUT 2 D-INPUT 4	Sets a function for the selected digital input. Any function can be set to any digital input. The input is activated when the potential free contact is Closed to B+ or input is +24V. If the number in front of the value/function name is negative (like -1 START POWERPACK) then the input is activated when the potential free contact is Open or input is 0V. If two or more inputs is set for the same function, then the function will be activated if only one of the inputs is active and all inputs must be deactivated to deactivate the function.
	0-NOT IN USE (default)	Digital input is not in use and deactivated
	-1/1-START POWERPACK	When the input is activated the AC power-pack will start running. For this function to work the VFD(AC) must be selected in parameter 1001-POWERPACK CONFIG. This function has a time-out of 15 minutes. Activating this input will suspend the stabilizer operation until timeout or input deactivated.
	-2/2-PRESSURE FILTER	When the input is activated for 5 seconds a pressure filter warning signal will be sent to all joystick panels and alert the captain that the filter needs to be replaced.
	-3/3-RETURN FILTER	When the input is activated for 5 seconds a return filter warning signal will be sent to all joystick panels and alert the captain that the filter needs to be replaced.
	-4/4 – E-STOP BOW	Use this EMERGENCY STOP BOW input with an external emergency stop button. When the input is activated, the BOW thruster will stop and trig a “Emergency Stop” fault code. This fault will not auto reset when deactivated but need an acknowledge from panel or on PHC-3.
	-5/5 – E-STOP STERN	Use this EMERGENCY STOP STERN input with an external emergency stop button. When the input is activated, the STERN thruster will stop and trig a “Emergency Stop” fault code. This fault will not auto reset when deactivated but need an acknowledge from panel or on PHC-3.
	-6/6-START AUX PRESSURE	When the input is activated the AC power-pack will start running with pressure target set in 1014-AUX SETPOINT or if reduced power function is activated, at the reduced power setting pressure. Note that 1014 AUX SETPOINT value must be within the motor capacity (45*Pressure/600), and the relief valve must be adjusted to a higher pressure. Maximum pressure is also limited by the installed stabilizer pressure sensor range 1010 minus 10 bar (default 160 bar). For this function to work the VFD(AC) must be selected in parameter 1001-STABILIZER CONFIG and parameter 1002-AUTO-START AC PUMP must also be set to ON. This function has a time-out of 15 minutes. Activating this input will suspend the stabilizer operation until timeout or input deactivated.

4.6 PARAMETERS - 10 POWERPACK

		PARAMETERS	POWERPACK
		03-COOLING PUMP 05-DIGITAL OUTPUTS 06-DIGITAL INPUTS 10-POWERPACK	1001-POWERPACK CONFIG PTO and VFD(AC) 1002-AUTO-START AC PUM 1003-PRESSURE SETPOINT
		6/8	✓=EDIT 1/18
No.	Name/Value	Description	
1001	POWERPACK CONFIG	Activating stabilizer power pack configuration.	
	NONE (default)	Disables stabilizer power pack function	
	PTO and VFD(AC)	Enables stabilizer to run from PTO and VFD	
	PTO ONLY	Enables stabilizer to run from PTO pressure only	
	VFD(AC) ONLY	Enables stabilizer to run from AC power only	
1002	AUTO-START AC PUMP	Defines if the AC power pack should start automatically.	
	OFF	Stabilizer system cannot start AC power pack automatically. PHC-3 manual operation and START POWERPACK digital input function can start power pack.	
	ON (default)	AC power pack starts automatically when stabilizer required it to run.	
1003	PRESSURE SETPOINT	Stabilizer AC power pack pressure setpoint	
	10bar – 1010 PRESSURE SENSOR RANGE (default 70bar)	Pressure in steps of 1bar	
1004	PID P FACTOR	AC power pack PID P factor	
	0.1 - 1000.0 (default 8.0)	In steps of 0.1	
1005	PID I FACTOR	AC power pack PID I factor	
	0.0 - 1000.0 (default 0.0)	In steps of 0.1	
1006	PID D FACTOR	AC power pack PID D factor	
	0.0 - 1000.0 (default 0.0)	In steps of 0.1	
1007	REDUCED POWER		
	DISABLE (default)	Disables the function and AC power pack will operate at set-point set in parameter 1003	
	ENABLE	Will operate the AC power pack with a lower set-point to save power	
1008	REDUCED POW.LEVEL	Setting the reduced power level to operate at percent level of pressure set-point (parameter 1003). The reduced level in bar must not go lower than the working pressure of the accumulator.	
	50% - 100% (default 70%)	Level in steps of 1%.	
1009	PTO PUMP PRESSURE DETECT LEVEL	Defines detection level for PTO standby pressure if parameter 0104 SYSTEM PRESSURE is set to ANALOG INPUT. Pressure above level indicates that main engines are running.	
	0bar – 100bar (default 10bar)	Pressure in steps of 1bar.	
1010	PRESSURE SENSOR RANGE	Sets the stabilizer pressure sensor range (4-20mA sensor)	
	50bar - 1000bar (default 160bar)	Range in steps of 10bar.	
1011	PTO ENGINE INSTANCE	This parameter is only in use when any digital output is set to function -8/8-STAB.PTO P.UNLOAD. Then this parameter must define the instance of the engine which the PTO pump is connected to. This also require that the engine is connected to the NMEA2000 bus on a GW-1 gateway and that the engine are broadcasting PGN127488 Engine Parameters.	
	0-255 (default 255)	Engines begins on the Port side with instance number 0 and increments towards Starboard. When editing one up from value 255 will jump to value 0.	
1012	VFD FLOW COMPENSATION	If the AC power-pack is having a hard time to retain the pressure at set-point. Then this factor will give a compensation to the stabilizer pressure regulation when running from AC power-pack. If value is set to 0.0 then there is no compensation.	
	0.0 - 2.0 (default 0.0)	In steps of 0.1	
1013	PTO OVER-PRESSURE FAULT LEVEL	The stabilizer overpressure fault level when stabilizer gets oil pressure from PTO. (When running on AUX pressure, the over-pressure fault level is 1014 AUX PRESSURE SETPOINT +30bar)	
	50bar-500bar (default 130bar)	In steps of 1bar	

4.6 PARAMETERS - 10 POWERPACK

1014	AUX PRESSURE SETPOINT	Pressure setpoint when Digital Input function START AUX PRESSURE is activated.
	Min: 70% of 1003 PRESSURE SETPOINT (default) Max: 200bar or 1010 PRESSOR SENSOR RANGE -10bar if the sensor is lower.	In steps of 1 bar.
1020	VFD MIN SPEED	Sets VFD Minimum Speed
	MIN LIMIT – MAX SPEED (default 200rpm)	The value is limited to VFD settings and parameter 1021 VFD MAX SPEED. ACS580 – sets parameter 4606 ‘Speed ref zero scaling’ (must be higher than ACS580 parameter 3011 ‘minimum speed’) . In steps of 10rpm.
1021	VFD MAX SPEED	Sets VFD Maximum Speed
	MIN SPEED – MAX LIMIT (default 1500rpm)	The value is limited to VFD settings and parameter 1020 VFD MIN SPEED. ACS580 – sets parameter 4601 ‘Speed scaling’ (must be lower than ACS580 parameter 3012 ‘maximum speed’). In steps of 10rpm.
1022	VFD TYPE	Selects VFD type
	ABB ACS550	ABB ACS550 Drive with Modbus connection
	VACON	VACON NX Drive with MODBUS/N2 option board with Modbus connection
	ABB ACS580 (default)	ABB ACS580 Drive with Modbus connection
	EHP	eVision Hydraulic Powerpack, DC motor. This is a S-link device and RS485/VFD connector shall not be used.
1023	VFD BAUD	Defines VFD Modbus communication speed. VFD must be set to same communication speed. Changing value requires power off/on of PHC-3 to take action. Changing communication settings on VFD will also require power off/on of VFD. This parameter is not in use if 1022 VFD TYPE is set to EHP.
	BAUD19200,8,EVEN,1	19.2 Kbit, 8bit data, parity EVEN, 1 stop bit
	BAUD38400,8,EVEN,1	34.8 Kbit, 8bit data, parity EVEN, 1 stop bit
	BAUD57600,8,EVEN,1 (default)	57.6 Kbit, 8bit data, parity EVEN, 1 stop bit
	BAUD115200,8,EVEN,1	115.2Kbit, 8bit data, parity EVEN, 1 stop bit

4.7 PARAMETERS - 20 BOW THRUSTER

PARAMETERS		BOW THRUSTER	
05-DIGITAL OUTPUTS		2001-VALVE TYPE	
06-DIGITAL INPUTS		DEACTIVATED	
10-STABILIZER		2002-DIRECTION	
20-BOW THRUSTER		2003-MAX SPOOL TRAVEL	
	7/8	✓=EDIT	1/7

No.	Name/Value	Description
2001	VALVE TYPE	Defines the bow proportional thruster valve
	DEACTIVATED	Deactivates the bow thruster function
	DANFOSS PVG (default)	Defines Danfoss PVG valve
2002	DIRECTION	Defines thruster direction. If the thruster operates to the wrong direction just change the setting here instead swapping hydraulic hoses on the installation. This parameter will affect the BOW valve output direction for all parameter 0102-THRUSTER CONFIG settings.
	NORMAL (default)	Normal thruster direction
	SWAPPED	Swapped thruster direction
2003	MAX SPOOL TRAVEL	Scaling of valves spool travel (valve opening) for optimized oil flow and dynamics. For bow spool travel optimization see 5.1. DIAGNOSTIC – BOW THRUSTER.
	50% - 100% (default 100%)	In steps of 1%
2004	RAMP INCREASE	Defines the time the output signal uses to go from 0% to 100%
	100ms – 10000ms (default 200ms)	In steps of 100ms
2005	RAMP DECREASE	Defines the time the output signal uses to go from 100% to 0%
	100ms – 10000ms (default 200ms)	In steps of 100ms
2006	DIRECTION LOCK	Defines the time from thruster has stopped to the output can change direction of thrust
	500ms – 10000ms (default 1000ms)	In steps of 100ms

4.7 PARAMETERS - 20 BOW THRUSTER (Cont.....)

2007	CROSSOVER	All 412mm (16inch), 513mm (20inch) and 610mm (24inch) tunnel thrusters, are supplied with hydraulic bypass/crossover valve and must therefore enable crossover. Disable crossover for all other thrusters. This crossover valve is normally open to protect the thruster during deceleration and will close while thruster is running. When changing to enable crossover the RAMP DECREASE parameter is set to 3000ms, and if changing to disable the RAMP DECREASE parameter are set to default value. Crossover can also be enabled to other D-OUTPUT's, see PARAMETERS - 05-DIGITAL OUTPUTS.
	DISABLE	Disables crossover
	DO-1 BOW CROSSOVER	Enables crossover to D-OUTPUT 1, NO Valve
	DO-1 -BOW CROSSOVER	Enables crossover to D-OUTPUT 1 Inverted output, NC Valve
2008	FUNCTION	Sets the bow thruster function to tunnel thruster or retract thruster. If PHC-3 detects and bow retract controller, then it will change function automatically to SRHP. Changing back to SH must be done manually.
	NORMAL (default)	Tunnel proportional thruster
	SRHP	Retract proportional thruster. With this function set the bow thruster will not run before the retractable tunnel is deployed.
2009	ASYMMETRIC THRUST	This setting can be used to improve performance of dual bow or stern thruster installations such as those found on catamarans or vessels with stern drive units. Pushing water at high flow into an adjacent tunnel may result in cavitation and reduction of thrust for the nearby tunnel. Pushing water towards the drive unit, above a certain flow rate, might not further increase the thrust. Thus for vessels with stern drive and dual thruster installation the current consumption could potentially be improved by reducing flow towards the drive unit while not reducing maximum achieved thrust. The Asymmetric Thrust value limits maximum thrust in one direction. The limiting direction is determined by the parameter 0101-INSTANCE of the PHC-3. PHC-3 with 0101-INSTANCE set to NONE or PORT will limit thrust towards port side and hence reduce the water flow towards starboard. PHC-3 with 0101-INSTANCE set to STARBOARD will limit thrust towards starboard side and hence reduce the water flow towards port.
	0 – 100% (default 100%)	The output limit level is expressed on a scale of 0% to 100%, where 100% signifies no limitations, and 0% corresponds to no output. Requested input is scaled to the output limit. In steps of 1%.

4.8 PARAMETERS - 21 STERN THRUSTER

PARAMETERS
06-DIGITAL INPUTS
10-STABILIZER
20-BOW THRUSTER
21-STERN THRUSTER
8/8

STERN THRUSTER
2101-VALVE TYPE
DEACTIVATED
2102-DIRECTION
2103-MAX SPOOL TRAVEL
✓=EDIT
1/7

No.	Name/Value	Description
2101	VALVE TYPE	Defines the stern proportional thruster valve
	DEACTIVATED	Deactivates the stern thruster function
	DANFOSS PVG (default)	Defines Danfoss PVG valve
2102	DIRECTION	Defines thruster direction. If the thruster operates to the wrong direction just change the setting here instead swapping hydraulic hoses on the installation. This parameter will affect the STERN valve output direction for all parameter 0102-THRUSTER CONFIG settings.
	NORMAL (default)	Normal thruster direction
	SWAPPED	Swapped thruster direction
2103	MAX SPOOL TRAVEL	Scaling of valves spool travel (valve opening) for optimized oil flow and dynamics. For stern spool travel optimization see 5.2. DIAGNOSTIC – STERN THRUSTER.
	50% - 100% (default 100%)	In steps of 1%
2104	RAMP INCREASE	Defines the time the output signal uses to go from 0% to 100%
	100ms – 10000ms (default 200ms)	In steps of 100ms
2105	RAMP DECREASE	Defines the time the output signal uses to go from 100% to 0%
	100ms – 10000ms (default 200ms)	In steps of 100ms
2106	DIRECTION LOCK	Defines the time from thruster has stopped to the output can change direction of thrust
	500ms – 10000ms (default 1000ms)	In steps of 100ms
2107	CROSSOVER	All 412mm (16inch), 513mm (20inch) and 610mm (24inch) tunnel thrusters, are supplied with hydraulic bypass/crossover valve and must therefore enable crossover. Disable crossover for all other thrusters. This crossover valve is normally open to protect the thruster during deceleration and will close while thruster is running. When changing to enable crossover the RAMP DECREASE parameter is set to 3000ms, and if changing to disable the RAMP DECREASE parameter are set to default value. Crossover can also be enabled to other D-OUTPUT's, see PARAMETERS - 05-DIGITAL OUTPUTS.
	DISABLE	This crossover valve is normally open to protect the thruster during
	DO-2 STERN CROSSOVER	Enables crossover to D-OUTPUT 2, NO Valve
	DO-2 -STERN CROSSOVER	Enables crossover to D-OUTPUT 2 Inverted output, NC Valve
2108	FUNCTION	Sets the stern thruster function to tunnel thruster or retract thruster. If PHC-3 detects and stern retract controller, then it will change function automatically to SRHP. Changing back to SH must be done manually.
	NORMAL (default)	Tunnel proportional thruster
	SRHP	Retract proportional thruster. With this function set the stern thruster will not run before the retractable tunnel is deployed.
2109	ASYMMETRIC THRUST	This setting can be used to improve performance of dual bow or stern thruster installations such as those found on catamarans or vessels with stern drive units. Pushing water at high flow into an adjacent tunnel may result in cavitation and reduction of thrust for the nearby tunnel. Pushing water towards the drive unit, above a certain flow rate, might not further increase the thrust. Thus for vessels with stern drive and dual thruster installation the current consumption could potentially be improved by reducing flow towards the drive unit while not reducing maximum achieved thrust. The Asymmetric Thrust value limits maximum thrust in one direction. The limiting direction is determined by the parameter 0101-INSTANCE of the PHC-3. PHC-3 with 0101-INSTANCE set to NONE or PORT will limit thrust towards port side and hence reduce the water flow towards starboard. PHC-3 with 0101-INSTANCE set to STARBOARD will limit thrust towards starboard side and hence reduce the water flow towards port.
	0 – 100% (default 100%)	The output limit level is expressed on a scale of 0% to 100%, where 100% signifies no limitations, and 0% corresponds to no output. Requested input is scaled to the output limit. In steps of 1%.

5. Menu - DIAGNOSTIC

MENU
ACTIVE FAULTS
DEVICE INFO
PARAMETERS
DIAGNOSTIC
4/5

5.1 DIAGNOSTIC - Bow Thruster

<table border="1" style="width: 100%; border-collapse: collapse;"> <tr><td style="text-align: center;">DIAGNOSTIC</td></tr> <tr><td>BOW THRUSTER</td></tr> <tr><td>STERN THRUSTER</td></tr> <tr><td>STABILIZER</td></tr> <tr><td>DIGITAL OUTPUTS</td></tr> <tr><td style="text-align: right;">1/7</td></tr> </table>	DIAGNOSTIC	BOW THRUSTER	STERN THRUSTER	STABILIZER	DIGITAL OUTPUTS	1/7	Shows live update of inputs and outputs related to bow thruster function.
DIAGNOSTIC							
BOW THRUSTER							
STERN THRUSTER							
STABILIZER							
DIGITAL OUTPUTS							
1/7							
<table border="1" style="width: 100%; border-collapse: collapse;"> <tr><td style="text-align: center;">BOW THRUSTER</td></tr> <tr><td>Joystick: 25%</td></tr> <tr><td>Output: 15.8V 63%</td></tr> <tr><td>Crossover: 1</td></tr> <tr><td>Sys.Pressure: 49 bar</td></tr> <tr><td>Spool Travel: 100%</td></tr> </table>	BOW THRUSTER	Joystick: 25%	Output: 15.8V 63%	Crossover: 1	Sys.Pressure: 49 bar	Spool Travel: 100%	
BOW THRUSTER							
Joystick: 25%							
Output: 15.8V 63%							
Crossover: 1							
Sys.Pressure: 49 bar							
Spool Travel: 100%							
In Display	Description						
Joystick: 25%	The amount of thrust from the joystick/control device. Negative value indicates thrust to port side.						
Output: 15.8V 63%	Valve signal voltage and spool travel (valve opening) in percent. Negative value indicates thrust to the opposite direction.						
Crossover: 1	Indicates if the crossover valve is activated. 0=deactivated, 1=activated, - =no crossover output defined						
Sys.Pressure: 49 bar	System pressure						
Spool Travel: 100%	Shows what the MAX SPOOL TRAVEL parameter 2003 is set to. Output are limited to this value.						
	Bow spool travel optimization: <ol style="list-style-type: none"> 1. Set MAX SPOOL TRAVEL parameter 2003 to 100%. 2. Enter this menu DIAGNOSTIC – BOW THRUSTER. 3. With a joystick panel (PJC) increase the bow thrust slowly to you reach maximum thrust and maximum Sys.Pressure. 4. Set MAX SPOOL TRAVEL parameter 2003 to what Output in % shows at maximum thrust and maximum Sys.Pressure. 						

5.2 DIAGNOSTIC - STERN THRUSTER

<table border="1" style="width: 100%; border-collapse: collapse;"> <tr><td style="text-align: center;">DIAGNOSTIC</td></tr> <tr><td>BOW THRUSTER</td></tr> <tr><td>STERN THRUSTER</td></tr> <tr><td>STABILIZER</td></tr> <tr><td>DIGITAL OUTPUTS</td></tr> <tr><td style="text-align: right;">2/7</td></tr> </table>	DIAGNOSTIC	BOW THRUSTER	STERN THRUSTER	STABILIZER	DIGITAL OUTPUTS	2/7	Shows live update of inputs and outputs related to stern thruster function.
DIAGNOSTIC							
BOW THRUSTER							
STERN THRUSTER							
STABILIZER							
DIGITAL OUTPUTS							
2/7							
<table border="1" style="width: 100%; border-collapse: collapse;"> <tr><td style="text-align: center;">STERN THRUSTER</td></tr> <tr><td>Joystick: -27%</td></tr> <tr><td>Output: 8.1V -65%</td></tr> <tr><td>Crossover: 1</td></tr> <tr><td>Sys.Pressure: 49 bar</td></tr> <tr><td>Spool Travel: 100%</td></tr> </table>	STERN THRUSTER	Joystick: -27%	Output: 8.1V -65%	Crossover: 1	Sys.Pressure: 49 bar	Spool Travel: 100%	
STERN THRUSTER							
Joystick: -27%							
Output: 8.1V -65%							
Crossover: 1							
Sys.Pressure: 49 bar							
Spool Travel: 100%							
In Display	Description						
Joystick: -27%	The amount of thrust from the joystick/control device. Negative value indicates thrust to port side.						
Output: 8.1V -65%	Valve signal voltage and spool travel (valve opening) in percent. Negative value indicates thrust to port side.						
Crossover: 1	Indicates if the crossover valve is activated. 0=valve open, 1=valve closed, - =no crossover output defined						
Sys.Pressure: 49 bar	System pressure						
Spool Travel: 100%	Shows what the MAX SPOOL TRAVEL parameter 2103 is set to. Output is limited to this value.						
	Stern spool travel optimization: <ol style="list-style-type: none"> 1. Set MAX SPOOL TRAVEL parameter 2103 to 100%. 2. Enter this menu DIAGNOSTIC – STERN THRUSTER. 3. With a joystick panel (PJC) increase the stern thrust slowly to you reach maximum thrust and maximum Sys.Pressure. 4. Set MAX SPOOL TRAVEL parameter 2103 to what Output in % shows at maximum thrust and maximum Sys.Pressure. 						

5.3 DIAGNOSTIC - STABILIZER

<p>DIAGNOSTIC</p> <p>BOW THRUSTER</p> <p>STERN THRUSTER</p> <p>STABILIZER</p> <p>DIGITAL OUTPUTS</p> <p>3/7</p>	<p>Shows live update of inputs and outputs related stabilizer function.</p>
<p>STABILIZER</p> <p>Sys.Pressure: 113 bar</p> <p>Stab.Pressure: 90 bar</p> <p>Power Request: YES</p> <p>Source: PTO</p> <p>Stab:1 Unload:0 Dump:1</p>	
<p>In Display</p>	<p>Description</p>
<p>Sys.Pressure: 113 bar</p>	<p>System Pressure (PTO/PVG pressure)</p>
<p>Stab.Pressure: 90 bar</p>	<p>Stabilizer Pressure</p>
<p>Power Request YES</p>	<p>Stabilizer Request Power</p>
<p>Source: PTO</p>	<p>Stabilizer Power Source. NONE, PTO or VFD (AC)</p>
<p>Stab:1 Unload:0 Dump:1</p>	<p>Stabilizer Vales Status. 0=0V, 1=valve has power (24V) Stab=Stabilizer, Unload=AC Pump Unload, Dump=Accumulator Dump</p>

5.4 DIAGNOSTIC - DIGITAL OUTPUTS

<p>DIAGNOSTIC</p> <p>BOW THRUSTER</p> <p>STERN THRUSTER</p> <p>STABILIZER</p> <p>DIGITAL OUTPUTS</p> <p>4/7</p>	<p>Shows live update of a valve output or digital output. 0 = output is 0 Volt 1 = output is energized</p> <p>When an output is highlighted, the output will be toggled as long as the ✓Enter button is being pushed and held.</p>
<p>DIGITAL OUTPUTS</p> <p>LS-Dump 0</p> <p>Pump #2 Shutdown 1</p> <p>Stabilizer 0</p> <p>AC Pump Unload 0</p> <p>✓ TOGGLES OUTPUT 1/12</p>	
<p>In Display</p>	<p>Description</p>
<p>LS-Dump</p>	<p>LS-Dump Valve</p>
<p>Pump #2 Shutdown</p>	<p>Pump #2 Shutdown Valve</p>
<p>Stabilizer</p>	<p>Stabilizer Valve</p>
<p>AC Pump Unload</p>	<p>AC Pump Unload valve</p>
<p>Accumulator Dump</p>	<p>Accumulator Dump Valve</p>
<p>Cooling Hydraulic</p>	<p>Hydraulic Cooling Pump</p>
<p>D-OUTPUT 1</p>	<p>Digital Output 1, See Parameter 0501 for output function</p>
<p>D-OUTPUT 2</p>	<p>Digital Output 2, See Parameter 0502 for output function</p>
<p>D-OUTPUT 3</p>	<p>Digital Output 3, See Parameter 0503 for output function</p>
<p>D-OUTPUT 4</p>	<p>Digital Output 4, See Parameter 0504 for output function</p>
<p>D-OUTPUT 5</p>	<p>Digital Output 5, See Parameter 0505 for output function</p>
<p>D-OUTPUT 6</p>	<p>Digital Output 6, See Parameter 0506 for output function</p>

5.5 DIAGNOSTIC - ANALOG INPUTS

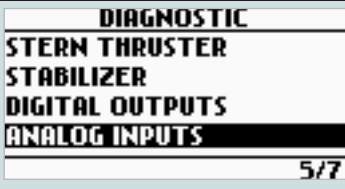
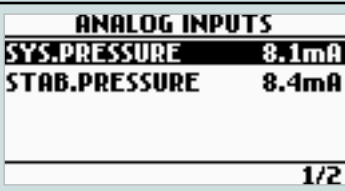
 <p>DIAGNOSTIC STERN THRUSTER STABILIZER DIGITAL OUTPUTS ANALOG INPUTS 5/7</p>	<p>Shows live update of analog inputs.</p>
 <p>ANALOG INPUTS SYS.PRESSURE 8.1mA STAB.PRESSURE 8.4mA 1/2</p>	<p>Shows analog input values in mA</p>
<p>In Display</p>	<p>Description</p>
<p>SYS.PRESSURE</p>	<p>System Pressure in mA. 4.0mA = 0bar</p>
<p>STAB.PRESSURE</p>	<p>Stabilizer Pressure in mA. 4.0mA = 0bar</p>

5.6 DIAGNOSTIC - DIGITAL INPUTS

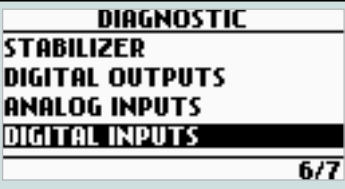
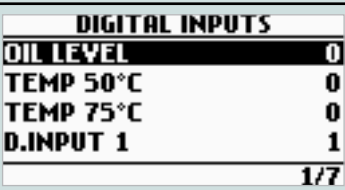
 <p>DIAGNOSTIC STABILIZER DIGITAL OUTPUTS ANALOG INPUTS DIGITAL INPUTS 6/7</p>	<p>Shows live update of digital inputs. 0 = input is shorted to 0 Volt (activated) 1 = input is open (deactivated)</p> <p>Scroll down to view more inputs.</p>
 <p>DIGITAL INPUTS OIL LEVEL 0 TEMP 50°C 0 TEMP 75°C 0 D.INPUT 1 1 1/7</p>	
<p>In Display</p>	<p>Description</p>
<p>OIL LEVEL</p>	<p>Oil Level</p>
<p>TEMP 50°C</p>	<p>Temp switch 50°C, warning level</p>
<p>TEMP 75°C</p>	<p>Temp switch 75°C, alarm level</p>
<p>D.INPUT 1</p>	<p>Digital Input 1</p>
<p>D.INPUT 2</p>	<p>Digital Input 2</p>
<p>D.INPUT 3</p>	<p>Digital Input 3</p>
<p>D.INPUT 4</p>	<p>Digital Input 4</p>





5.7 DIAGNOSTIC - S-LINK BUS

<pre> DIAGNOSTIC DIGITAL OUTPUTS ANALOG INPUTS DIGITAL INPUTS S-LINK BUS 7/7 </pre>	<p>Shows live update of S-link bus (CAN-bus) error status for PHC-3.</p>
<pre> S-LINK BUS Rx Error Count: 0 Tx Error Count: 0 Last Error: No Error Flag: </pre>	<p>Showing no error and signal condition is good.</p>
<pre> S-LINK BUS Rx Error Count: 52 Tx Error Count: 0 Last Error: BitDominant Flag: WARNING BUS OFF </pre>	<p>Example showing lots of error and very bad signal conditions.</p> <p>NB! When S-link devices are hot plugged or disconnected to the bus or powered (when AMS is engaged and powering PPC and retract), it is not unusual to see some values been incremented. But they will quickly decrement to 0 again. This will not cause any communication issues.</p>
<p>In Display</p>	<p>Description</p>
<p>Rx Error Count</p>	<p>Receive error counter. Error during reception increments the value. After every successful reception the value is decremented.</p>
<p>Tx Error Count</p>	<p>Transmit error counter. Error during transmit increments the value. After every successful transmit the value is decremented.</p>
<p>Last Error</p>	<p>Indicates the error condition of the last error detected. If a message has been transferred or received without error, it will show No Error. Conditions: No Error, STUFF, FORM, ACK(Acknowledgment), BitRecessive, BitDominant & CRC.</p>
<p>Flag</p>	<p>BUS OFF: when Tx Error Count is greater than 255 and overflowed. (Tx Error Count will show 0 when in BUS OFF state) WARNING: when Rx Error Count or Tx Error Count has reached 96 counts PASSIVE: when Rx Error Count or Tx Error Count is more than 127 counts</p>

6. Menu - MANUAL OPERATION

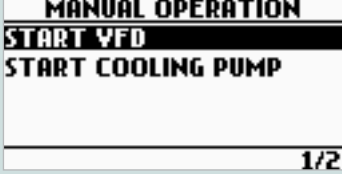
MENU
DEVICE INFO
PARAMETERS
DIAGNOSTIC
MANUAL OPERATION
5/5

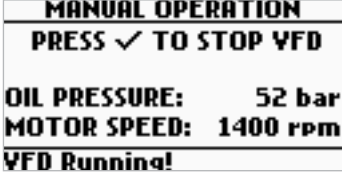
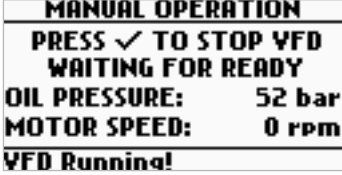
6.1 MANUAL OPERATION - START VFD

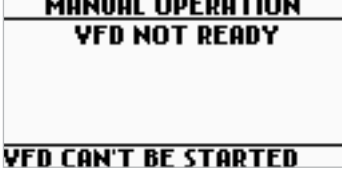
	<p>Option to manually operate VFD for service or commission purposes. Enter this menu to operate the VFD when having problems, and the information in the display can give useful feedback to service personnel.</p>
<p>In Display</p>	<p>Description</p>
	<p>VFD are ready and pressing ✓Enter will start VFD.</p>
	<p>VFD is running. Stabilizer pressure and motor speed is displayed. While VFD is running it is possible to press ⬅Back and go to parameters and change parameter values like 1003 PRESSURE SETPOINT, or view DIGITAL OUTPUTS.</p>
	<p>Waiting for power management system to allow VFD start.</p>
	<p>Error screen informing that the PHC-3 controller is not able to communicate with the VFD, probable causes is:</p> <ul style="list-style-type: none"> - VFD not powered up - VFD communication cable not connected to PHC - VFD communication cable is incorrectly wired to VFD terminals
	<p>VFD in local (LOC) mode, switch to remote (REM) to be able to run VFD from PHC-3.</p>

6.2 MANUAL OPERATION - Start Cooling Pump

<p>MANUAL OPERATION START YFD START COOLING PUMP</p> <p style="text-align: right;">2/2</p>	<p>Option to manually start cooling pump for service or commission purposes. The status information in the display can give useful feedback to service personnel. While cooling pump is running it's possible to press Back and go to parameters and change parameter values like 0303 ECI PUMP SPEED, or view DIGITAL OUTPUTS.</p>
<p>In Display</p>	<p>Description</p>
<p>MANUAL OPERATION ELECTRIC ECI OIL TEMP 33°C ECI S:00 M:82 0rpm DCA: 0.0A MOTA: 0.0A ✓ TO START COOLING</p>	<p>ECI cooling pump is selected in parameter 0301 and is ready to be operated.</p>
<p>MANUAL OPERATION ELECTRIC ECI OIL TEMP 33°C ECI S:00 M:82 1406rpm DCA: 3.1A MOTA: 12.4A ✓ TO STOP COOLING</p>	<p>ECI cooling pump is running and the following data is shown in this example: -Hydraulic oil temperature 33°C -ECI cooling pump S: 00 (controller status) -ECI cooling pump M: 82 (motor status) -ECI cooling pump motor speed 1406rpm -ECI cooling pump DC current 3.1A -ECI cooling pump motor peak current 12.4A</p>
<p>MANUAL OPERATION HYDRAULIC GREY HARNESS OIL TEMP 36°C ✓ TO START COOLING</p>	<p>Hydraulic cooling pump is selected in parameter 0301 and is ready to be operated. The following data is shown in this example: -Hydraulic oil temperature 36°C If you just want to test the output when there is no oil pressure, see chapter 1.5.4 DIAGNOSTIC – DIGITAL OUTPUTS.</p>
<p>MANUAL OPERATION D-OUT 4 BLUE HARNESS OIL TEMP 33°C ✓ TO START COOLING</p>	<p>Electric cooling pump on D-OUT 4 is selected in parameter 0301 and is ready to be operated. The following data is shown in this example: -Hydraulic oil temperature 33°C</p>
<p>MANUAL OPERATION CC MODULE OIL TEMP 36°C CCM AC STATUS: 0x00 CCM DC STATUS: 0x00 ✓ TO START COOLING</p>	<p>CC Module (Cooling Control Module) is selected in parameter 0301. -Hydraulic oil temperature 36°C -CCM AC STATUS: 0000 (AC pump status from CC Module) xxx1 = AC Cooling pump is running xx1x = AC Cooling pump is forced running 1xxx = AC Cooling pump fault -CCM DC STATUS: 0000 (DC pump status from CC Module) xxx1 = DC Cooling pump is running xx1x = DC Cooling pump is forced running 1xxx = DC Cooling pump fault</p>

Fault situations in S-Link compliant products generates Fault Codes which are broadcasted on the S-Link bus. If a control panel receives a Fault Code, it will trigger an alarm in the control panel and the user will be able to get information about which product that reports the fault and the reason for the fault. Please see the user manual of your S-Link compliant control panel for more information on how to access Fault Code information in case of an alarm situation.

All Sleipner S-Link compliant products have product specific Fault Codes. For legacy reasons some control panels display Generic Fault Codes for certain products.

Fault Code Navigator

Scan the QR code below to access Sleipner's Fault Code Navigator. Fault codes can be entered in the Fault Code Navigator to receive fault description and guidance on resolving the issue.

A complete list of fault codes and troubleshooting tips can also be downloaded.



www.sleipnergroup.com/support/fault-code-navigator

Responsibility of the installer

MC_0038

General:

- The installer must read this document to ensure necessary familiarity with the product before installation.
- Directions outlined in this document cannot be guaranteed to comply with all international and national regulations, including but not limited to health and safety procedures. It is the installers responsibility to adhere to all applicable international and national regulations when installing Sleipner products.
- This document contains general installation guidelines intended to support experienced installers. Contact professional installers familiar with the vessel, Sleipner products and applicable regulations if assistance is required.
- If local regulation requires any electrical work to be performed by a licensed professional, seek a licensed professional.
- When planning the installation of Sleipner products, ensure easy access to the products for future service and inspection requirements.

For Sleipner S-Link™ systems:

MC_0105

- When installing an S-Link™ system, connect ONLY original Sleipner S-Link™ products or other authorized control equipment directly to the S-Link™ bus. When connecting non-authorized third-party equipment, it must always be connected through a Sleipner-supplied interface product.
- Any attempt to directly control or connect to the S-Link™ control system without a designated and approved interface from Sleipner will void all warranties and responsibilities of the connected Sleipner products. If you interface the S-Link™ bus by agreement with Sleipner through a designated Sleipner-supplied interface, you are still required to install at least one original Sleipner control panel to enable efficient troubleshooting if necessary.

Supply Voltage	9-31 VDC
Power consumption	Less than 1.0 Watt in stand-by
Digital output 1 to 6	Max load 2.0 Amp pr. output
Digital inputs	0-31 VDC
Operating temperature	-20°C to +70°C / -4°F to +158°F
Weight	700g / 24,7oz
IP rating PHC-3	IP65
IP rating 73830 Thruster Control Cabinet	IP65 (Gland for S-Link: IP54)

PHC-3 Dimensions

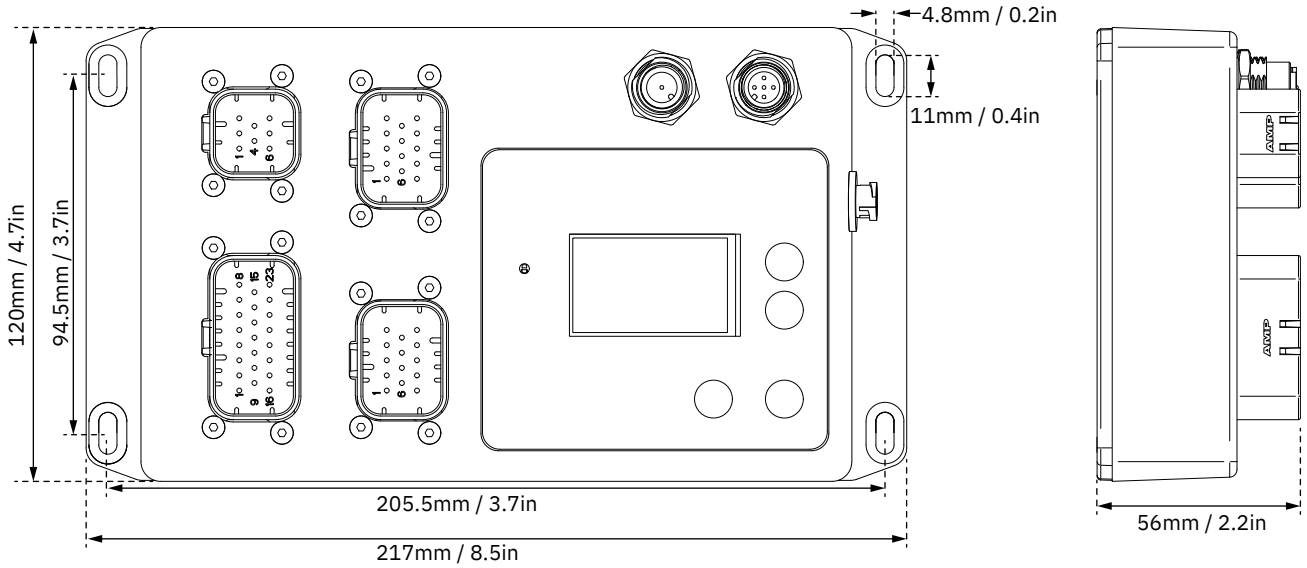

MG_0652

73830 Thruster Control Cabinet Dimensions

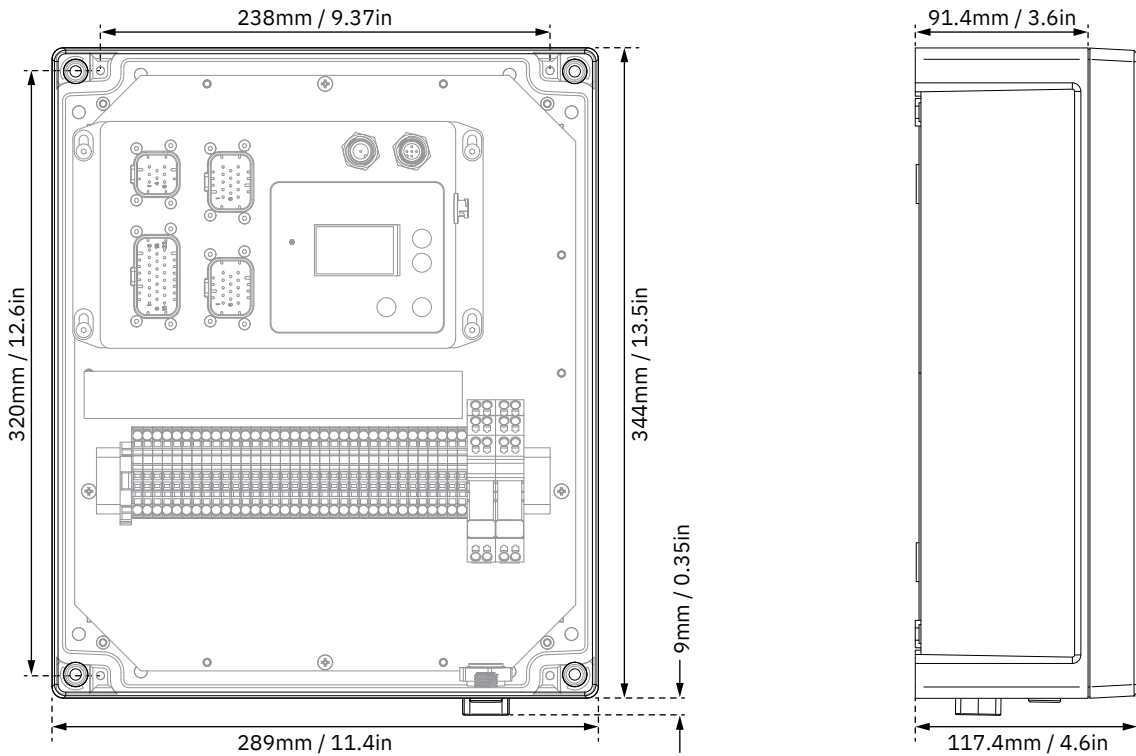

MG_0653

Hydraulic System

For Hydraulic Systems the PHC-3 controller is pre-mounted on the frame.

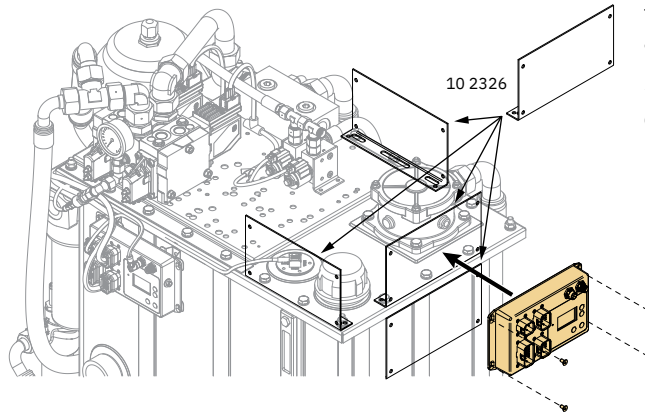
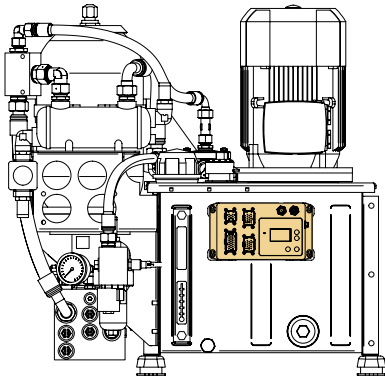

To improve access to the PHC-3 after the Hydraulic System is installed in a vessel, the bracket 10 2326 with order nr. SM178023 can be used. Ensure that the cable harness reaches the new location before mounting the bracket.

MG_0672

Standalone

1. Mount PHC-3 in the desired location using four counter sunk screws, max 1Nm. Excessive force might damage the mounting flange.
2. Attach the required cables to the PHC-3

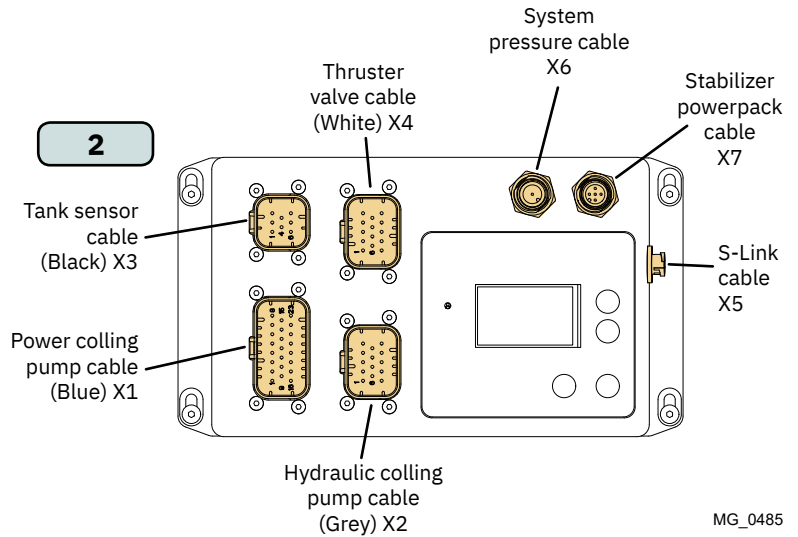
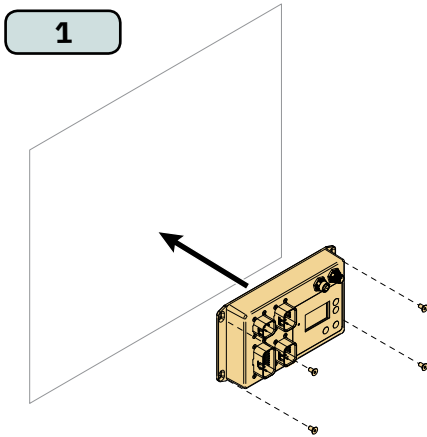

MG_0485

Junction Box

1. Drill holes and mount the required number of cable glands. It is recommended to mount the cable glands on the bottom wall of the enclosure.
2. Remove lid and mount the 73830 Thruster Control Cabinet in the desired location, using four screws.
3. Connect wires to terminal blocks according to project specific drawings. Connect S-Link Spur cable of desired length and enter the junction box through the split grommet

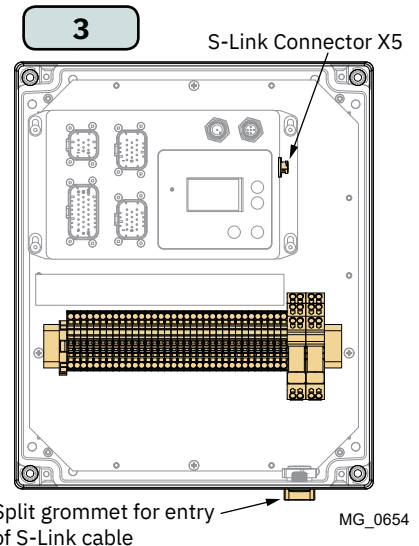
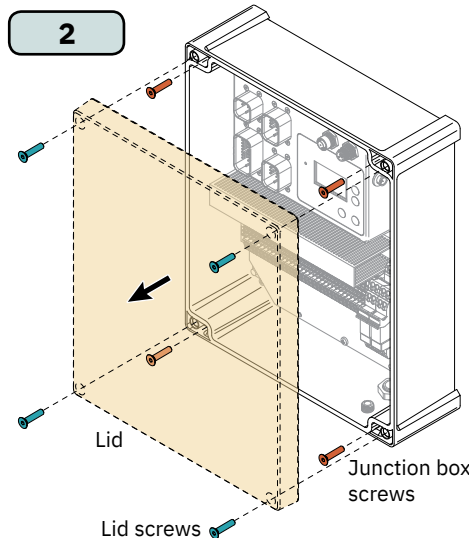
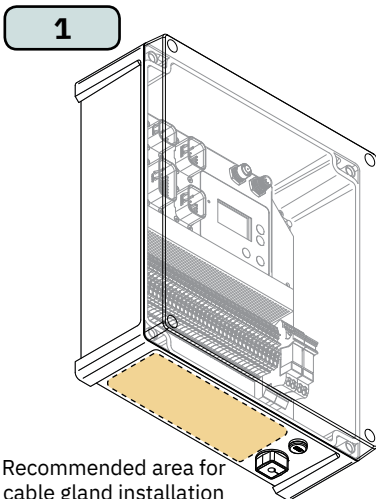

MG_0654

S-Link is a CAN-based control system used for communication between Sleipner products installed on a vessel. The system uses BACKBONE Cables as a common power and communication bus with separate SPUR Cables to each connected unit. Only one S-Link POWER cable shall be connected to the BACKBONE Cable. Units with low power consumption are powered directly from the S-Link bus.

Main advantages of S-Link system:

- Compact and waterproof plugs.
- BACKBONE and SPUR Cables have different colour coding and keying to ensure correct and easy installation. BACKBONE Cables have blue connectors and SPUR Cables have green connectors.
- Different cable lengths and BACKBONE Extenders make the system scalable and flexible to install.

Installation of S-Link cables:

Select appropriate cables to keep the length of BACKBONE- and SPUR Cables to a minimum. In case of planned installation with total BACKBONE Cable length exceeding 100 meters please consult your local distributor. The S-Link cables should be properly fastened when installed to avoid sharp bend radius, cable chafing and undesired strain on connectors. Locking mechanism on connectors must be fully closed. To ensure long lifetime, cables, T-Connectors and Extenders should not be located so that they are permanently immersed in water or other fluids. It is recommended to install cables in such a way that water and condensation do not flow along the cables into the connectors. This can be done for example by introducing a u-shape bend before the cable enters the product connector.

Ideally, the POWER Cable should be connected to the middle of the BACKBONE bus to ensure an equal voltage drop at both ends of the BACKBONE Cable. The yellow and black wire in the POWER Cable shall be connected to GND and the red wire connected to +12VDC or +24VDC.

To reduce the risk of interference, avoid routing the S-Link cables close to equipment such as radio transmitters, antennas or high voltage cables. The backbone must be terminated at each end with the END Terminator.

SPUR cables can be left unterminated to prepare for the installation of future additional equipment. In such cases, ensure to protect open connectors from water and moisture to avoid corrosion in the connectors.

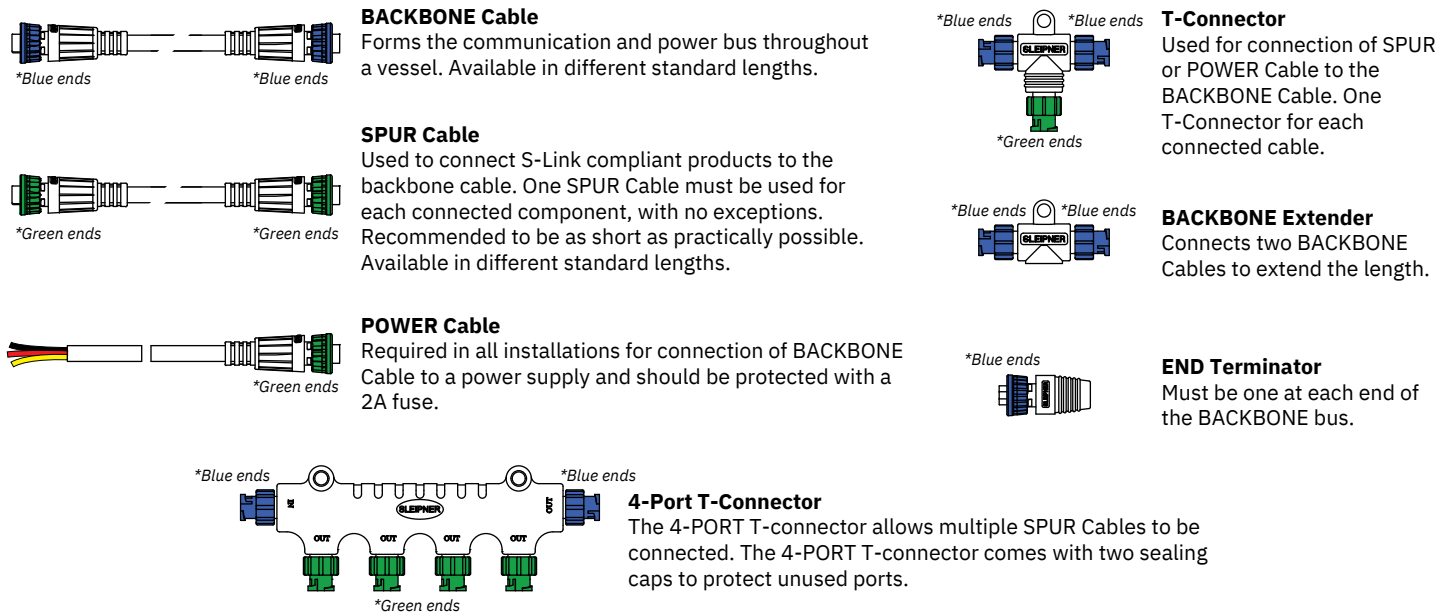

S-Link installation example

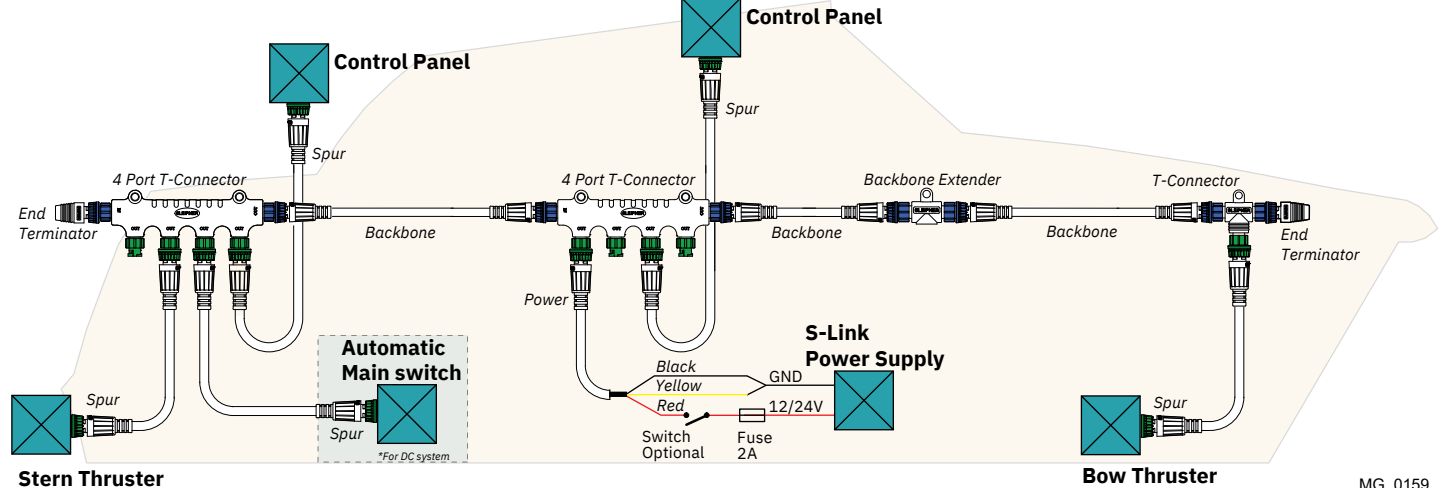

Introduction:

At Sleipner Group, we prioritize sustainability and encourage the repair and re-manufacturing of products to extend their life cycles. If disposal is necessary, please follow these guidelines to recycle and manage waste responsibly, ensuring our efforts align with environmental protection efforts.

Electric Motors and Electronics:

- Disconnect from any power sources and dismantle them carefully.
- Recycle components through certified e-waste recycling centers that can adequately handle and recover electronic materials.
- Dispose of any non-recyclable electronic parts according to local environmental regulations.

Metals:

- Collect and sort metal parts for recycling as scrap metal.
- To increase recycling efficiency, ensure that metals are clean and free from non-metal attachments.

Plastics:

- Identify recyclable plastics based on local recycling guidelines.
- Remove any non-plastic components and clean them before recycling to improve the quality of the recycled material.

Hazardous Materials:

- Correctly identify any hazardous substances within components, such as batteries or capacitors etc.
- Follow local regulations for the safe disposal of hazardous materials to prevent pollution and protect environmental health.

General Disposal Instructions:

- Consult local recycling programs to determine the acceptability of various materials.
- Use authorized disposal services to ensure compliance with environmental standards.

Safe Disposal Practices:

- Adhere to local laws and regulations for waste management to minimize environmental impact and ensure community safety.

This guide is designed to help reduce our products' environmental footprint through responsible end-of-life management. Please contact your local waste management supplier or our support team for more specific disposal information or further assistance.

Find your local professional dealer from our certified worldwide network for expert service and support. visit our website www.sleipnergrou.com/support

Product spare parts and additional resources

For additional supporting documentation, we advise you to visit our website www.sleipnergrou.com and find your Sleipner product.

Warranty statement

1. Sleipner Motor AS (The “Warrantor”) warrants that the equipment (parts, materials, and embedded software of products) manufactured by the Warrantor is free from defects in workmanship and materials for purpose for which the equipment is intended and under normal use and maintenance service (the “Warranty”).
2. This Warranty is in effect for two years (Leisure Use) or one year (Commercial and other Non-leisure Use) from the date of delivery/purchase by the end user, with the following exceptions;
 - (a) For demonstration vessels, or vessels kept on the water, the dealer is considered as the end user from 6 months after their launch of the vessel;
 - (b) The warranty period starts no later than 18 months after the first launch of the vessel.
 Please note that the boat manufacturer and dealer must pay particular attention to correct maintenance and service both by the products manuals as well as general good practice for the location the boat is kept in the period the boat is in their care. In cases where the 6 and 18 months grace periods for boat builders and dealers are passed, it is possible to obtain a full warranty upon inspection and approval of the warrantor or such representative.
3. Certain parts, classified as wearable or service parts, are not covered by the warranty. A failure to follow the required maintenance and service work as described in the product manual render all warranty on parts or components directly or indirectly affected by this void. Please also note that for some parts, time is also a factor separately from actual operational hours.
4. This Warranty is transferable and covers the equipment for the specified warranty period.
5. The warranty does not apply to defects or damages caused by faulty installation or hook-up, abuse or misuse of the equipment including exposure to excessive heat, salt or fresh water spray, or water immersion except for equipment specifically designed as waterproof.
6. In case the equipment seems to be defective, the warranty holder (the “Claimant”) must do the following to make a claim:
 - (a) Contact the dealer or service centre where the equipment was purchased and make the claim. Alternatively, the Claimant can make the claim to a dealer or service centre found at www.sleipnergrou.com. The Claimant must present a detailed written statement of the nature and circumstances of the defect, to the best of the Claimant’s knowledge, including product identification and serial nbr., the date and place of purchase and the name and address of the installer. Proof of purchase date should be included with the claim, to verify that the warranty period has not expired;
 - (b) Make the equipment available for troubleshooting and repair, with direct and workable access, including dismantling of furnishings or similar, if any, either at the premises of the Warrantor or an authorised service representative approved by the Warrantor. Equipment can only be returned to the Warrantor or an authorised service representative for repair following a pre-approval by the Warrantor’s Help Desk and if so, with the Return Authorisation Number visible postage/shipping prepaid and at the expense of the Claimant.
7. Examination and handling of the warranty claim:
 - (a) If upon the Warrantor’s or authorised service Representative’s examination, the defect is determined to result from defective material or workmanship in the warranty period, the equipment will be repaired or replaced at the Warrantor’s option without charge, and returned to the Purchaser at the Warrantor’s expense. If, on the other hand, the claim is determined to result from circumstances such as described in section 4 above or a result of wear and tear exceeding that for which the equipment is intended (e.g. commercial use of equipment intended for leisure use), the costs for the troubleshooting and repair shall be borne by the Claimant;
 - (b) No refund of the purchase price will be granted to the Claimant, unless the Warrantor is unable to remedy the defect after having a reasonable number of opportunities to do so. In the event that attempts to remedy the defect have failed, the Claimant may claim a refund of the purchase price, provided that the Claimant submits a statement in writing from a professional boating equipment supplier that the installation instructions of the Installation and Operation Manual have been complied with and that the defect remains.
8. Warranty service shall be performed only by the Warrantor, or an authorised service representative, and any attempt to remedy the defect by anyone else shall render this warranty void.
9. No other warranty is given beyond those described above, implied or otherwise, including any implied warranty of merchantability, fitness for a particular purpose other than the purpose for which the equipment is intended, and any other obligations on the part of the Warrantor or its employees and representatives.
10. There shall be no responsibility or liability whatsoever on the part of the Warrantor or its employees and representatives based on this Warranty for injury to any person or persons, or damage to property, loss of income or profit, or any other incidental, consequential or resulting damage or cost claimed to have been incurred through the use or sale of the equipment, including any possible failure or malfunction of the equipment or damages arising from collision with other vessels or objects.
11. This warranty gives you specific legal rights, and you may also have other rights which vary from country to country.

Patents

At Sleipner we continually reinvest to develop and offer the latest technology in marine advancements. To see the many unique designs we have patented, visit our website www.sleipnergrou.com/patents

© **Sleipner Motor AS**, All rights reserved

The information given in the document was right at the time it was published. However, Sleipner Motor AS cannot accept liability for any inaccuracies or omissions it may contain. Continuous product improvement may change the product specifications without notice. Therefore, Sleipner Motor AS cannot accept liability for any possible differences between product and document.

Learn more about our products at
www.sleipnergroun.com



SLEIPNER MOTOR AS

P.O. Box 519

N-1612 Fredrikstad

Norway

www.sleipnergroun.com

Made in Norway