



Installation Guide

For Clamp Flanges



DOCUMENT ID: 3058

REVISION: 2

DATE: 2024

LANGUAGE: EN

MI

General:

- The installer must read this document to ensure necessary familiarity with the product before installation.
- Directions outlined in this document cannot be guaranteed to comply with all international and national regulations, including but not limited to health and safety procedures. It is the installers responsibility to adhere to all applicable international and national regulations when installing Sleipner products.
- This document contains general installation guidelines intended to support experienced installers. Contact professional installers familiar with the vessel and applicable regulations if assistance is required.
- If local regulation requires any electrical work to be performed by a licensed professional, seek a licensed professional.
- When planning the installation of Sleipner products, ensure easy access to the products for future service and inspection requirements.

Mounting The Clamp Flange To The Shaft

1. Ensure clamp flange is correct according to efficacy and shaft.
2. Clean clamp and shaft, and remove if there are any burrs.
3. Carefully expand the flange slot with a wedge or similar. **(NB: Do not damage the flange or shaft.)**
4. Run the shaft to the inner position where the shaft is 1mm from the clamp flange front edge. *Fig.1*
5. Remove wedge.
6. Apply oil/grease on all bolts. *Fig.1*
7. Tighten all bolts until you feel resistance.
8. Torque the bolts to 20Nm as shown in the pattern below. *Fig.2*
9. Torque the bolts in 3 sequences as shown in the pattern below, and in accordance with table. *Fig.2*

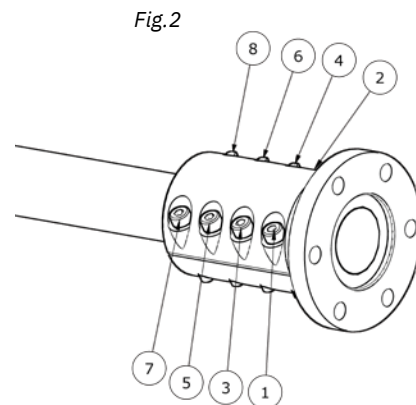
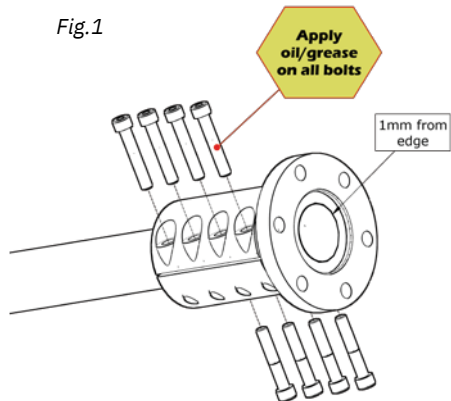

	M10	M12	M16
1	40 Nm	70 Nm	150 Nm
2	60 Nm	100 Nm	220 Nm
3	75 Nm	130 Nm	330 Nm

Mounting The Clamp Flange To The Gear

1. Ensure that the engine is geared/positioned in order to standard.
2. Apply oil/grease on all bolts.
3. Tighten all bolts until you feel resistance.
4. Torque the bolts to 20Nm in a cross pattern as shown below. Fig.4
5. Torque the bolts in a cross pattern according to table below. Fig.4

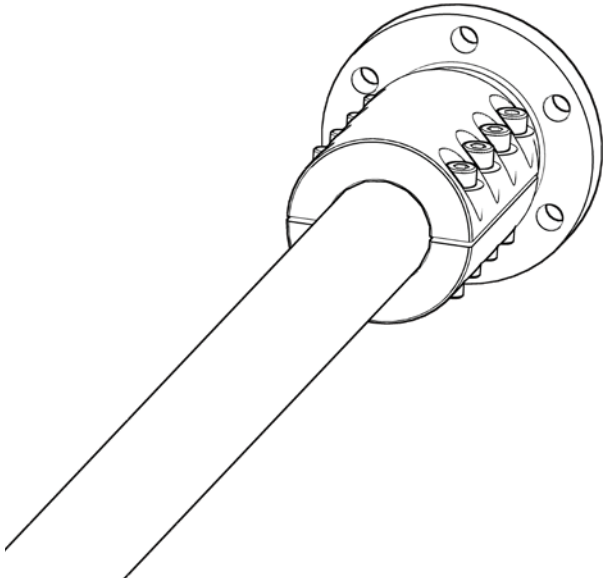
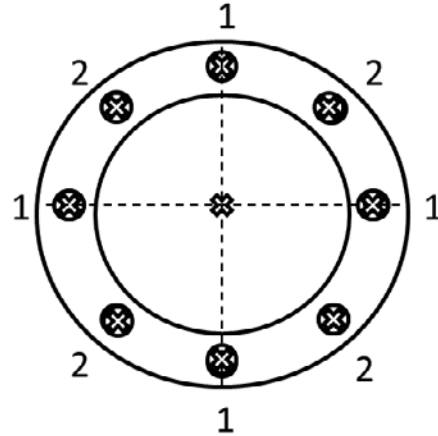

Fig.4



M10	M12	M12	7/16"
45 Nm	70 Nm	180 Nm	65 Nm

© **Sleipner Group**, All rights reserved
The information given in the document
was right at the time it was published.
However, Sleipner Group cannot
accept liability for any inaccuracies or
omissions it may contain. Continuous
product improvement may change the
product specifications without notice.
Therefore, Sleipner Group cannot accept
liability for any possible differences
between product and document.

Learn more about our products at
www.sleipnergroun.com



SLEIPNER MOTOR AS

P.O. Box 519

N-1612 Fredrikstad

Norway

www.sleipnergroun.com

Made in Norway