

Installation guide Clamp flange



Mounting of clamp flange to shaft

1. Ensure clamp flange is correct according to efficacy and shaft.
2. Clean clamp and shaft, and remove if there are any burrs.
3. Carefully expand the flange slot with a wedge or similar. **Note! Do not damage the flange or shaft.**
4. Run the shaft to the inner position where the shaft is 1mm from the clamp flange front edge. Fig.1.
5. Remove wedge.
6. Apply oil/grease on all bolts. Fig.1.
7. Tighten all bolts until you feel resistance.
8. Torque the bolts to 20Nm as shown in the pattern below. Fig.2.
9. Torque the bolts in 3 sequences as shown in the pattern below, and in accordance with table. Fig.2.

Fig.1

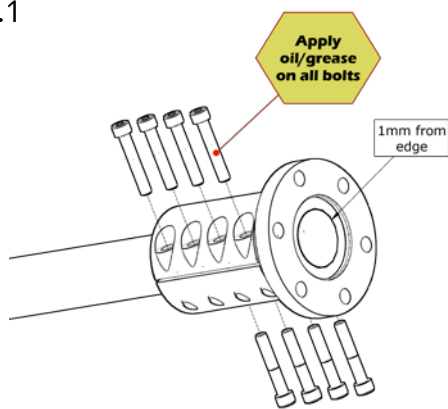
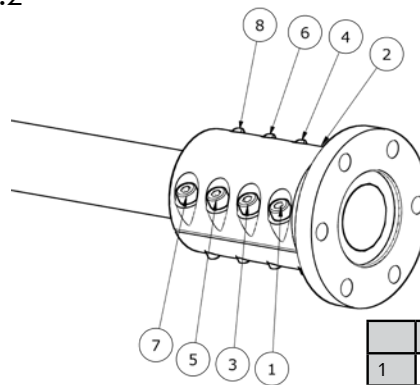

Fig.2



	M10	M12	M16
1	40Nm	70Nm	150Nm
2	60Nm	100Nm	220Nm
3	75Nm	130Nm	300Nm

Mounting of clamp flange to gear

1. Ensure that the engine is geared/positioned in order to standard.
2. Apply oil/grease on all bolts.
3. Tighten all bolts until you feel resistance.
4. Torque the bolts to 20Nm in a cross pattern as shown below. Fig.4.
5. Torque the bolts in a cross pattern according to table below. Fig.4.

Fig.3

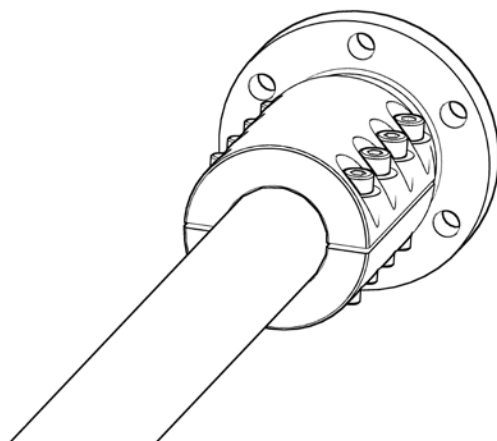
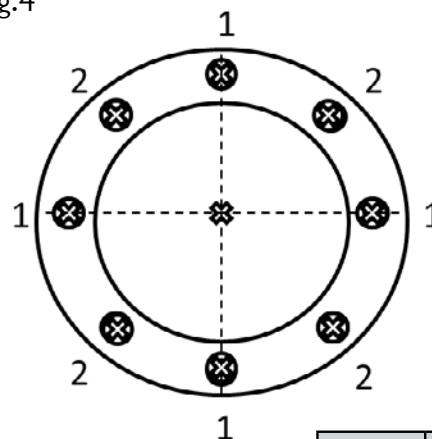

Fig.4



M10	M12	M16	7/16"
45Nm	70Nm	180Nm	65Nm