

User Manual

Sleipner Electric Stabilizers



User Manual

| | |
|---|-----|
| Warnings & Safety | 3 |
| General Operation and Precaution Guidelines | 4 |
| Operation | 5-7 |
| Alarms and Warnings..... | 8-9 |
| Updating S-Link Devices | 10 |
| Remote Control..... | 11 |
| Fault Code Readout and Logging..... | 12 |
| Fault Code Navigator | 13 |
| Maintenance..... | 14 |
| Service and Support | 15 |
| Spare Parts and Additional Resources | 15 |
| Patents | 15 |
| Warranty Statement | 16 |
| Sleipner Group Waste Disposal and Recycling Guide | 17 |

This manual must accompany the product at all times, in digital or printed format.

Products Covered

- SPS40E-24/48V DC Electric Stabilizer Actuator
- SPS50E-24/48V DC Electric Stabilizer Actuator
- SPS60E-24/48V DC Electric stabilizer actuator
 - SPS60E AC Electric Stabilizer Actuator
 - SPS70E AC Electric Stabilizer Actuator
 - SPS80E AC Electric Stabilizer Actuator
 - SPS100E AC Electric Stabilizer Actuator

To prevent personal injury, death, or damage to this product, the vessel, or other equipment, it is essential that you carefully follow all instructions in this manual during installation and operation. Failure to follow these instructions will immediately void all warranties provided by Sleipner Motor.

Warnings and notices throughout this document highlight situations that require special caution. Always pay close attention when these appear.



WARNING

Indicates a potentially hazardous situation which, if not avoided, could result in death or serious injury.



CAUTION

Indicates a potentially hazardous situation which, if not avoided, could result in minor or moderate injury or damage to the product.

MC_0800N



WARNING

Failure to follow any considerations and precautions can lead to serious personal injury, death and/or damage your product. Failure to follow any considerations and precautions will render all warranties given by Sleipner Motor as VOID.



WARNING

Never operate the stabilizer when people, pets, or objects are in the water nearby. Ensure the fins have clear space to move, and check for docks, mooring lines, or any submerged objects that could be struck when the fins activate. The fins may also extend outside the hull sides of the vessel, especially during docking alongside a quay, and could strike piers or other structures. Do not swim or bathe near the vessel while the stabilizers are active.

General Description

The Sleipner SPS E-Series Stabilizer System consists of two (or four) underwater movable fins, mounted on shaft and actuator assemblies that penetrate through each side of the yacht's hull. These fins are electrically powered either DC or AC, depending on the actuator size and controlled electronically via a gyro using the Sleipner S-Link (CANbus) network system. The system stabilizes the yacht's rolling motion both underway and at anchor, providing comfort across various speeds and sea conditions.

Before Activating the Stabilizer System

Review and understand all warnings and cautions highlighted.

Ensure the system is active whenever the yacht is operating in planing or semi-planing (fast) modes, even in calm water.



WARNING

Do not operate the yacht at high speeds with the stabilizer system deactivated. Fixed fins may cause unpredictable handling and excessive heel, increasing the risk of injury and vessel instability.

Why Continuous Activation Is Important

At high speeds, the yacht's wet surface area and direct hull forces are reduced, making the stabilizing fins essential for both roll reduction and maintaining predictable directional and heel stability. If the stabilizer system is deactivated, the fins remain in a fixed position, which can cause the yacht to behave unpredictably at high speeds. Keeping the system active ensures consistent and comfortable handling, improving comfort even in calm conditions. If the system cannot be activated due to malfunction or other reasons, do not exceed speeds at which misaligned fins could cause the yacht to heel.

Operating in Reverse

The fins should automatically center and lock when the yacht is shifted into reverse.

If the fins do not lock automatically (e.g., due to brake failure or reverse sensor malfunction), reverse the yacht at minimal speed only to prevent damage or unpredictable behavior.



CAUTION

If the fins do not lock automatically when shifting into reverse, operate only at minimal speed. Failure to do so may result in fin damage or unpredictable vessel behavior.

Activate Stabilizers

From the Home screen: Select STABILIZERS.

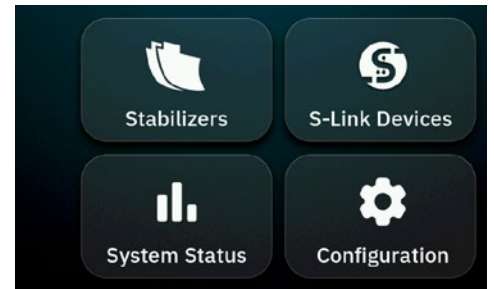

Panel

- A) Home screen
- B) Roll Angle
- C) Status
- D) Speed
- E) Panel ON/OFF
- F) Stabilizer Modes
- G) Return
- H) Stabilizer ON/OFF
- I) At Anchor (Activation)
- J) Screen Brightness

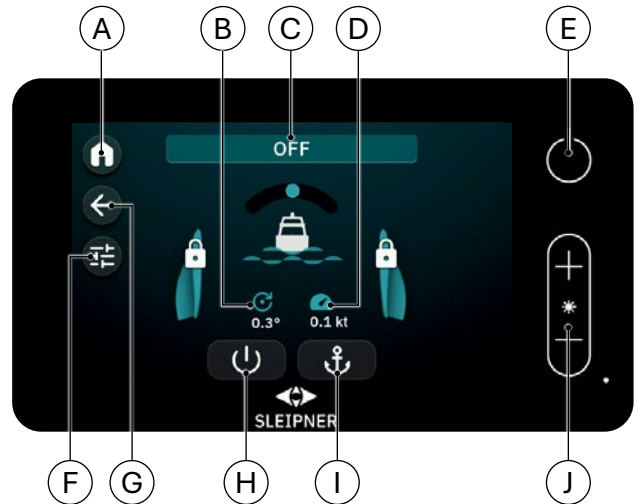

Cruising Mode

Select the Stabilizer ON/OFF button (H). The button switches to blue, and the fin lock symbols disappear. The stabilizers are now active in Cruising Mode, typically used at speeds of 3–4 knots and above. At speeds below, the system will seize operation, center and lock the fins. Operation will resume when speed is increased.



At Anchor Mode

Ensure the stabilizer system is powered ON (H). Select the Anchor button on the control panel (I). The button switches to blue to indicate At Anchor Mode is active. This mode is active at speeds from 0–4 knots. To deactivate, select the Anchor button again.



(NB: If both Cruising and At Anchor modes are activated, the system will automatically switch between them based on vessel speed. The system will turn OFF automatically if speed drops below 3 knots and At Anchor Mode is not enabled.)

Turn the System OFF

Select the ON/OFF button (H). The fins will center, become locked, and the system will be inactive. The system can also be turned ON/OFF via the PJC-2xx panel. Refer to the PJC-2xx manual for more information.

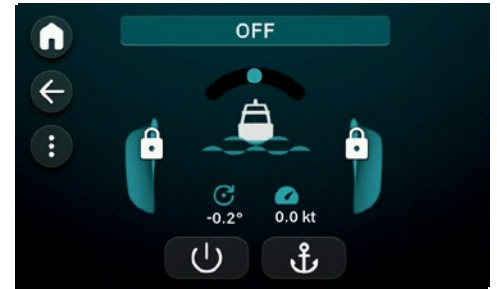

Stabilizer Modes

The stabilizer system offers multiple operating modes to optimize performance for different conditions and vessel activities. These modes can be activated via modes, from the home screen select (F). For quick access, you can pin your preferred modes, which will keep them available on the main display.

- Eco mode** Reduces power use by limiting fin activity to essential corrections, suitable for moderate sea states and fuel-efficient cruising. Eco mode will reduce power consumption and at the same time the roll reduction efficiency. *(Max fin angular velocity is reduced to 50-95% when eco mode is enabled.)*
- Park mode** Enables an alternative locked fin position, where the fins can be positioned as not to protrude the boat's envelope. Manual confirmation is required for the fins to change position after selecting or de-selecting the mode.
- Fishing mode** Protects the stabilizer fins during reverse movement. At low reverse speeds, the fins operate with limited movement, at higher reverse speeds, they free-float and stabilization pauses. Once the boat slows down, the fins recenter and lock automatically. This function works even if the stabilizer system is off. Speed limits are preset and not user-adjustable.
- Dynamic positioning** allows the system to operate even if the reverse is engaged, if the system is sensing that reverse is used to keep the boat in position, not to move it backwards.

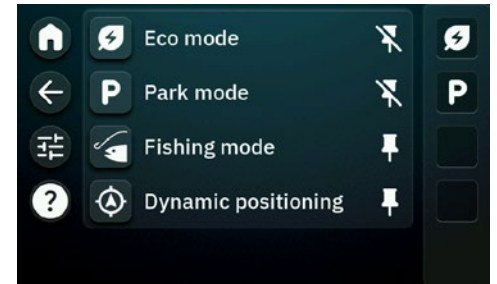

Gain

Limits the fin acceleration. Higher is not necessarily better, but allows the user to fine-tune to current conditions.

- At Anchor Adjusts the system's response to roll while at anchor.
- Adjusts the system's response to roll while cruising.



If the stabilizer system needs to run while docked in a confined space, activate Docking Mode to limit outboard fin travel. This prevents fins from extending beyond the boat's envelope and avoids potential contact with the dock or quay. Docking Mode must be set and activated individually for each fin to ensure proper operation in tight docking conditions.

Activating Docking Mode

Select the fin symbol for the fin you want to enable. Set Docking Mode to ON. The docking mode sector is defined in the stabilizer setup menu, and shown here in a different color when enabled.

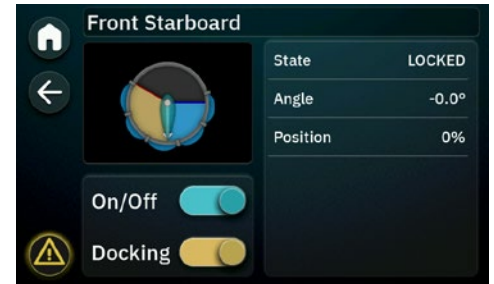

Disabled Fins

If a fin is disabled, this status will be displayed on the front screen. A fin can be disabled either due to an SCU (Stabilizer Control Unit) fault or because it has been manually turned off. Fins may be disabled for safety or operational reasons, including:

- To reduce forward forces.
- When at anchor and there is insufficient space to operate safely.
- When docked alongside a quay or another vessel.
- When people are swimming near the fin.



Backing the Yacht

When any gearbox is reversing, the fins will automatically center and lock. BACKING will be indicated on the screen. After reversing, the system will either resume operation or turn off, depending on the setting of Suspend Exit State. (Backing is a WARNING state, indicated by a yellow triangle.)

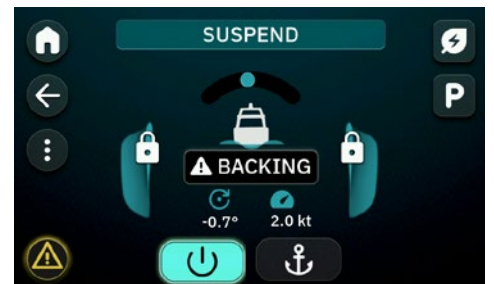

Alarms and Warnings are indicated in the bottom left corner of the screen.

- Alarms represent serious, immediate issues that require prompt attention or action.
- Warnings indicate potential or developing issues that should be monitored or addressed to prevent escalation. Normal operating states such as backing will appear as warnings. Entering Reduced Power Mode, High Temperature Derate, or Low Voltage Derate will also be shown as warnings.

Viewing Warnings

Select the yellow warning symbol to view the alarm and warning list.

The list shows current warnings, with descriptions. *(NB: Alarms and warnings can co-exist at the same time, so always check the list carefully to understand the system's status.)*

| Warning | Will prevent start of system |
|------------------------|------------------------------|
| DC undervoltage | Yes |
| GPS missing | Yes |
| High speed system off | No |
| Park mode | No |
| Eco mode/reduced power | No |
| Backing | No |

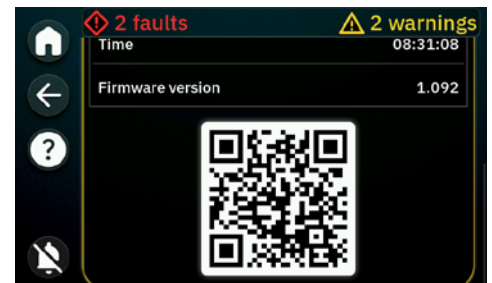
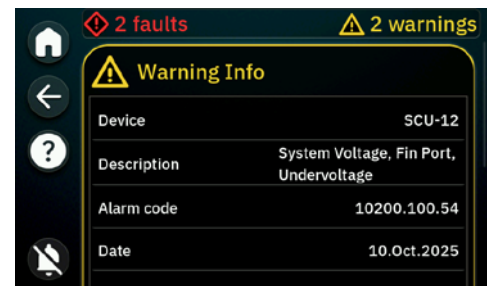
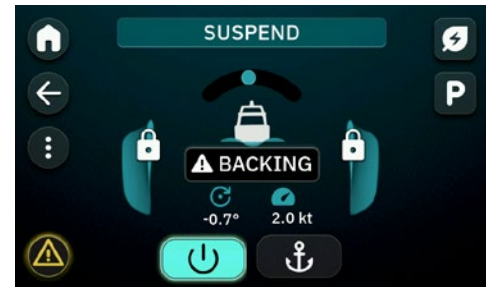

Viewing Alarms

Select the red alarm symbol to view alarm list. This list shows current alarms, with descriptions. Example: **power to actuators is lost during operation**. This results in a fault. As long as power is not restored, a warning will be displayed. Clearing the fault without resolving the underlying issue will not remove the warning. Each alarm entry provides a detailed description and a QR code for further information or troubleshooting guidance.

Clearing Alarms

Before selecting Clear All Alarms, you must perform the necessary actions to correct the problem and ensure the issue has been resolved. To clear alarms, select Clear All Alarms. **(NB: For new parts required to correct the alarm issue, contact a Sleipner representative.)**

Additional Support

Use the fault code navigator (<https://www.sleipnergrouper.com/fault-code-navigator>) to look up codes for troubleshooting guidance.

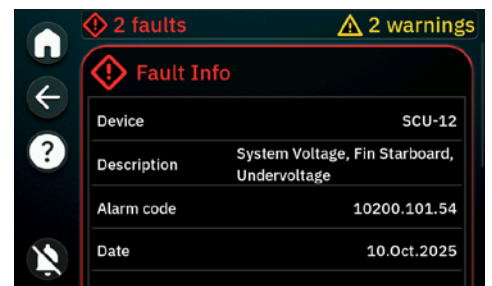
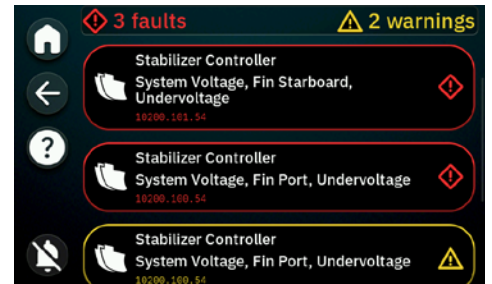

Internet Download

(NB: Make sure to have a stable S-Link network before proceeding to upgrade devices. If the upgrade fails due to bad communication, the device will be set in boot mode. Re-try upgrading. If the problem persists, repair S-Link communication fault before re-trying upgrade.)

1. Enable Network connection (Wireless or Ethernet)
2. Select S-Link Devices and choose the device you wish to update Example - Upgrading SCU-12.
3. Select Upgrade on the selected device.

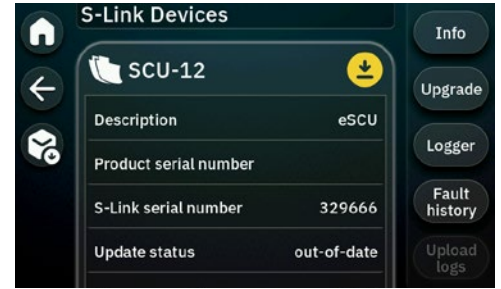

USB Download

Before downloading the S-Link Programmer, ensure you have access to the USB port located on the back of the control panel and a USB drive formatted as FAT32

1. Download S-Link Programmer (<https://side-power.com/slinkupgrade/S-Link-ProgrammerSetup.zip>)
2. Start the S-Link Programmer.
 - From the menu, open Tools, Download Manager.
 - Select S-Link Offline Upgrade and download the upgrade file to a high-quality USB stick (formatted FAT32).
3. Insert the USB stick into the USB port on the back of the stabilizer panel (or use the USB extension port, if installed).
4. Follow on screen instructions.

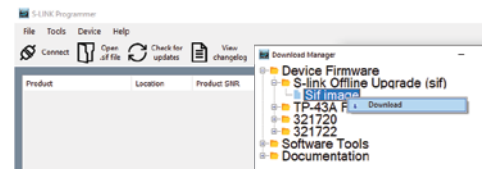

Remote Control Function

The Remote Control feature allows authorized Sleipner technicians to remotely view and adjust stabilizer system settings to assist with troubleshooting.

Remote Control

1. Open the Panel settings, general tab, Enter the boat name. This name will be used to identify files when uploading data to Sleipner support.
2. Enable Network connection. (Wireless or Ethernet)
3. Activate Remote Control, provide the PIN code displayed on the panel to your Sleipner technician, The technician can now initiate a remote login session.

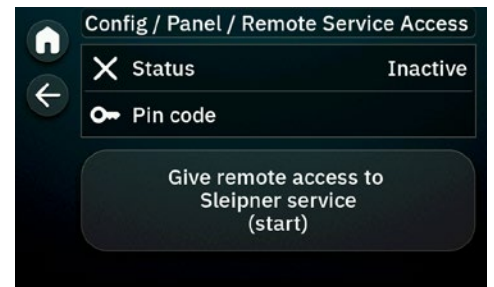

View Fault History

1. From the Home page, select S-Link Devices.
2. Select the desired device.
3. Select Fault History.
4. Create Fault History Log.
5. The Fault History list is displayed. Select an alarm to view more details.
6. The fault history can be uploaded when an active internet connection is established.

Additional Support

Use the fault code navigator (<https://www.sleipnergroup.com/fault-code-navigator>) to look up codes for troubleshooting guidance.



Logging

Some devices allow data logging. This should only be performed when: Specifically requested by Sleipner, or triggered remotely by Sleipner personnel.

1. To begin logging: Press the Log button on the selected device page.
2. Choose the logging mode according to instructions from Sleipner.
3. With an internet connection enabled: Press Upload Logs to send the data to the Sleipner server. Notify your Sleipner contact once the upload is complete.

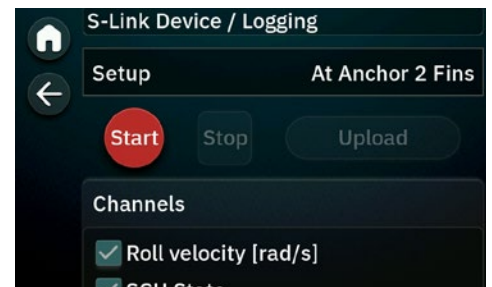

Scan the QR code below to access Sleipner's Fault Code Navigator.

Fault codes can be entered in the Fault Code Navigator to receive fault description and guidance on resolving the issue.

A complete list of fault codes and troubleshooting tips can also be downloaded.



www.sleipnergroun.com/support/fault-code-navigator

Fin Actuator Units

The stabilizer system is generally a low-maintenance product. However, as with all moving parts, some degree of preventive maintenance will increase system lifetime and reliability.

A chart with recommended inspection and service points is provided at the end of this section.

For all new installations, or after major component replacement, a basic inspection should be performed after the first 100 hours of operation or after the first week of proper use:

- “Shake” the fins from the outside to check for any play in the connections.

Whenever the vessel is hauled out of the water for service or any other reason, take the opportunity to check items that cannot be accessed while afloat. It is recommended to perform a thorough inspection of the fins and to do a proper cleaning this is also recommended during haul-out.

(NB: Because of the large variations in vessel type, usage, and operating conditions, it is not possible to accurately predict the service life of the main shaft bearings. Sleipner therefore recommends regular inspection and corrective action as required. Bearing clearances should be checked periodically when possible, in order to avoid unexpected haul-outs between planned service intervals.)

The service intervals indicated in the chart are based on calculations and experience. However, due to variations in operation and load (for example, different fin sizes fitted to the same actuator size), the service life of bearings and seals may be either longer or shorter than indicated.

Maintenance Intervals

The schedules in this section indicate the recommended preventive maintenance intervals for equipment supplied by Sleipner. Components not supplied by Sleipner, but used in Sleipner Stabilizer Systems, are not included in this schedule and are not covered by any Sleipner warranty.

Maintenance intervals are listed in hours of operation and time, where relevant. Maintenance must be performed at the specified interval, using whichever comes first (time or operating hours). The schedule incorporates the minimum required maintenance to ensure safe and correct operation of the system. Failure to follow these guidelines will void the warranty for the affected items.

| Maintenance intervals | | | | | | | | | |
|--|-----------------|------|------|-------|-------|-------|-------------------|---------------|---------------|
| Maintenance schedule | Service level * | 250h | 500h | 2000h | 4000h | 8000h | When out of water | When required | Months/Year |
| Inspect electrical connections | 1W | | | X | | | | | 12/every |
| Change oil of gear unit | 2D | | | | X | | X | | 36/third |
| Change gear transmission parts | 3W | | | | | X | | | |
| Change seals | 3D | | | | | X | X | | |
| Check oil magnet (fin must be removed) | 2D | | | | | | X | | When required |
| Clean fins and paint with antifouling | 2D | | | | | | X | X | |

| Service levels | |
|----------------|--|
| Service level | Description: |
| 1 | Onboard maintenance possible at sea, no shore support required |
| 2 | Shore supported maintenance and corrective measures |
| 3 | Trained personnel required |
| D | Dry - Vessel must be out of the water |
| W | Wet - Vessel can be in the water |

Find your local professional dealer from our certified worldwide network for expert service and support. visit our website www.sleipnergroupp.com/support

Spare Parts and Additional Resources

For additional supporting documentation, we advise you to visit our website www.sleipnergroupp.com and find your Sleipner product.

Patents

At Sleipner we continually reinvest to develop and offer the latest technology in marine advancements. To see the many unique designs we have patented, visit our website www.sleipnergroupp.com/patents

1. Sleipner Motor AS (The “Warrantor”) warrants that the equipment (parts, materials, and embedded software of products) manufactured by the Warrantor is free from defects in workmanship and materials for purpose for which the equipment is intended and under normal use and maintenance service (the “Warranty”).
2. This Warranty is in effect for two years (Leisure Use) or one year (Commercial and other Non-leisure Use) from the date of delivery/purchase by the end user, with the following exceptions:
 - (a) For demonstration vessels, or vessels kept on the water, the dealer is considered as the end user from 6 months after their launch of the vessel;
 - (b) The warranty period starts no later than 18 months after the first launch of the vessel.Please note that the boat manufacturer and dealer must pay particular attention to correct maintenance and service both by the products manuals as well as general good practice for the location the boat is kept in the period the boat is in their care. In cases where the 6 and 18 months grace periods for boat builders and dealers are passed, it is possible to obtain a full warranty upon inspection and approval of the warrantor or such representative.
3. Certain parts, classified as wearable or service parts, are not covered by the warranty. A failure to follow the required maintenance and service work as described in the product manual render all warranty on parts or components directly or indirectly affected by this void. Please also note that for some parts, time is also a factor separately from actual operational hours.
4. This Warranty is transferable and covers the equipment for the specified warranty period.
5. The warranty does not apply to defects or damages caused by faulty installation or hook-up, abuse or misuse of the equipment including exposure to excessive heat, salt or fresh water spray, or water immersion except for equipment specifically designed as waterproof.
6. In case the equipment seems to be defective, the warranty holder (the “Claimant”) must do the following to make a claim:
 - (a) Contact the dealer or service centre where the equipment was purchased and make the claim. Alternatively, the Claimant can make the claim to a dealer or service centre found at www.sleipnergroup.com. The Claimant must present a detailed written statement of the nature and circumstances of the defect, to the best of the Claimant’s knowledge, including product identification and serial nbr., the date and place of purchase and the name and address of the installer. Proof of purchase date should be included with the claim, to verify that the warranty period has not expired;
 - (b) Make the equipment available for troubleshooting and repair, with direct and workable access, including dismantling of furnishings or similar, if any, either at the premises of the Warrantor or an authorised service representative approved by the Warrantor. Equipment can only be returned to the Warrantor or an authorised service representative for repair following a pre-approval by the Warrantor’s Help Desk and if so, with the Return Authorisation Number visible postage/shipping prepaid and at the expense of the Claimant.
7. Examination and handling of the warranty claim:
 - (a) If upon the Warrantor’s or authorised service Representative’s examination, the defect is determined to result from defective material or workmanship in the warranty period, the equipment will be repaired or replaced at the Warrantor’s option without charge, and returned to the Purchaser at the Warrantor’s expense. If, on the other hand, the claim is determined to result from circumstances such as described in section 4 above or a result of wear and tear exceeding that for which the equipment is intended (e.g. commercial use of equipment intended for leisure use), the costs for the troubleshooting and repair shall be borne by the Claimant;
 - (b) No refund of the purchase price will be granted to the Claimant, unless the Warrantor is unable to remedy the defect after having a reasonable number of opportunities to do so. In the event that attempts to remedy the defect have failed, the Claimant may claim a refund of the purchase price, provided that the Claimant submits a statement in writing from a professional boating equipment supplier that the installation instructions of the Installation and Operation Manual have been complied with and that the defect remains.
8. Warranty service shall be performed only by the Warrantor, or an authorised service representative, and any attempt to remedy the defect by anyone else shall render this warranty void.
9. No other warranty is given beyond those described above, implied or otherwise, including any implied warranty of merchantability, fitness for a particular purpose other than the purpose for which the equipment is intended, and any other obligations on the part of the Warrantor or its employees and representatives.
10. There shall be no responsibility or liability whatsoever on the part of the Warrantor or its employees and representatives based on this Warranty for injury to any person or persons, or damage to property, loss of income or profit, or any other incidental, consequential or resulting damage or cost claimed to have been incurred through the use or sale of the equipment, including any possible failure or malfunction of the equipment or damages arising from collision with other vessels or objects.
11. This warranty gives you specific legal rights, and you may also have other rights which vary from country to country.

Introduction:

At Sleipner Group, we prioritize sustainability and encourage the repair and re-manufacturing of products to extend their life cycles. If disposal is necessary, please follow these guidelines to recycle and manage waste responsibly, ensuring our efforts align with environmental protection efforts.

Electric Motors and Electronics:

- Disconnect from any power sources and dismantle them carefully.
- Recycle components through certified e-waste recycling centers that can adequately handle and recover electronic materials.
- Dispose of any non-recyclable electronic parts according to local environmental regulations.

Metals:

- Collect and sort metal parts for recycling as scrap metal.
- To increase recycling efficiency, ensure that metals are clean and free from non-metal attachments.

Plastics:

- Identify recyclable plastics based on local recycling guidelines.
- Remove any non-plastic components and clean them before recycling to improve the quality of the recycled material.

Hazardous Materials:

- Correctly identify any hazardous substances within components, such as batteries or capacitors etc.
- Follow local regulations for the safe disposal of hazardous materials to prevent pollution and protect environmental health.

General Disposal Instructions:

- Consult local recycling programs to determine the acceptability of various materials.
- Use authorized disposal services to ensure compliance with environmental standards.

Safe Disposal Practices:

- Adhere to local laws and regulations for waste management to minimize environmental impact and ensure community safety.

This guide is designed to help reduce our products' environmental footprint through responsible end-of-life management. Please contact your local waste management supplier or our support team for more specific disposal information or further assistance.



SLEIPNER

Ocean born. Tech bred.

SLEIPNER MOTOR AS

P.O. Box 519

N-1612 Fredrikstad

Norway

www.sleipnergroup.com

Made in Norway

© Sleipner Motor AS, All rights reserved

The information given in the document was right at the time it was published. However, Sleipner Motor AS cannot accept liability for any inaccuracies or omissions it may contain. Continuous product improvement may change the product specifications without notice. Therefore, Sleipner Motor AS cannot accept liability for any possible differences between product and document. Learn more about our products at www.sleipnergroup.com