

# User Manual

## Sleipner Hydraulic Stabilizers



## User Manual

Warnings & Safety .....	3
General Operation and Precaution Guidelines .....	4
Operation .....	5-6
Alarms and Warnings.....	7-8
Updating S-Link Devices .....	9
Remote Control.....	10
Fault Code Readout and Logging.....	11
Fault Code Navigator .....	12
Service and Maintenance .....	13-16
Service and Support .....	17
Spare Parts and Additional Resources .....	17
Patents .....	17
Warranty Statement .....	18
Sleipner Group Waste Disposal and Recycling Guide .....	19

This manual must accompany the product at all times, in digital or printed format.

### Products Covered

- SPS55B – Hydraulic actuator
- SPS66B – Hydraulic actuator
- SPS67B-167 – Hydraulic actuator
- SPS67B-208 – Hydraulic actuator
- SPS92B – Hydraulic actuator
- SPS93B – Hydraulic actuator
- SPS94B-240 – Hydraulic actuator
- SPS94B-320 – Hydraulic actuator
- SPS96B – Hydraulic actuator
- SPS97B – Hydraulic actuator

To prevent personal injury, death, or damage to this product, the vessel, or other equipment, it is essential that you carefully follow all instructions in this manual during installation and operation. Failure to follow these instructions will immediately void all warranties provided by Sleipner Motor.

Warnings and notices throughout this document highlight situations that require special caution. Always pay close attention when these appear.



### WARNING

Indicates a potentially hazardous situation which, if not avoided, could result in death or serious injury.



### CAUTION

Indicates a potentially hazardous situation which, if not avoided, could result in minor or moderate injury or damage to the product.

MC\_0800N



## WARNING

Failure to follow any considerations and precautions can lead to serious personal injury, death and/or damage your product. Failure to follow any considerations and precautions will render all warranties given by Sleipner Motor as VOID.



## WARNING

Never operate the stabilizer when people, pets, or objects are in the water nearby. Ensure the fins have clear space to move, and check for docks, mooring lines, or any submerged objects that could be struck when the fins activate. The fins may also extend outside the hull sides of the vessel, especially during docking alongside a quay, and could strike piers or other structures. Do not swim or bathe near the vessel while the stabilizers are active.

## General Description

The Sleipner Stabilizer System consists of two underwater movable fins mounted on shafts and actuator assemblies that penetrate through each side of the yacht's hull. The system is hydraulically powered by a Sleipner Compact Hydraulic System and electronically gyro-controlled via the Sleipner S-link (CanBus) network. This system stabilizes the yacht's rolling motion at various speeds, sea conditions, and when at anchor (optional).

## Before Activating the Stabilizer System

Review and understand all warnings and cautions highlighted.

Ensure the system is active whenever the yacht is operating in planing or semi-planing (fast) modes, even in calm water.



## WARNING

Do not operate the yacht at high speeds with the stabilizer system deactivated. Fixed fins may cause unpredictable handling and excessive heel, increasing the risk of injury and vessel instability.



## CAUTION

Always ensure there are no leaks, the hydraulic oil level is correct, and the cooling pump is running. Continuously monitor system temperature and pressure on the panel while the system is in operation. The system must be powered either by one or both main engines, or by an alternative hydraulic power source (such as the AC powerpack).

## Operating Guidelines

Keep the stabiliser system active when operating the vessel in planning or semi-planning modes, even in calm water.

The stabilisers provide essential roll and directional stability, particularly at high speeds when hull forces are reduced.

Leaving the fins stationary can cause unexpected changes in handling at high speeds. With the system engaged, the vessel's motion will be predictable and comfortable in all conditions. If the system malfunctions, run at a maximum safe speed where the vessel's natural directional and roll stability can compensate.

## Reversing the Vessel



## CAUTION

If the fins do not lock automatically when shifting into reverse, operate only at minimal speed. Failure to do so may result in fin damage or unpredictable vessel behavior.

Only reverse at minimal speed if the fins are not in the LOCKED position.

The fins should automatically center and lock when reversing. If they do not (e.g., due to hydraulic or sensor failure), reduce speed immediately and reverse as slowly as possible until the issue is resolved.

## Activate Stabilizers

From the Home screen: Select STABILIZERS.

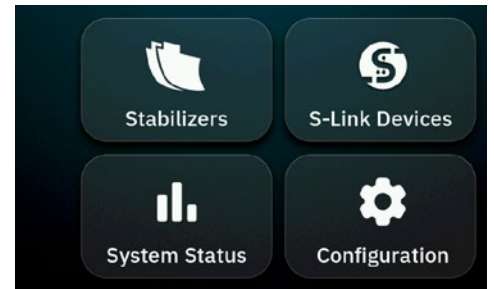

### Panel

- A) Home screen
- B) Roll Angle
- C) Status
- D) Speed
- E) Panel ON/OFF
- F) Stabilizer Modes
- G) Return
- H) Stabilizer ON/OFF
- I) At Anchor (Activation)
- J) Screen Brightness

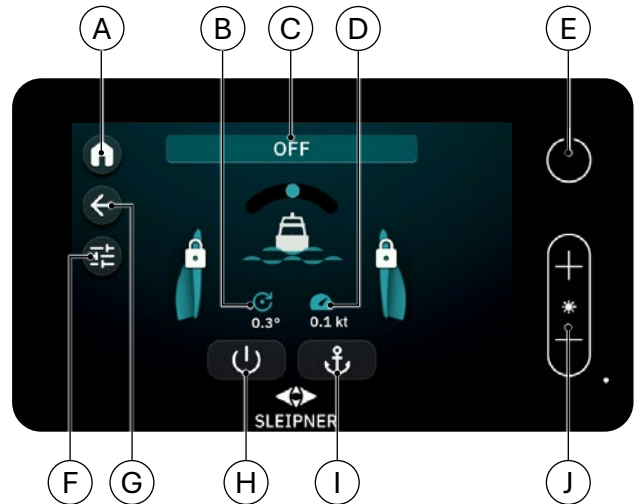

### Cruising Mode

Select the Stabilizer ON/OFF button (H). The button switches to blue, and the fin lock symbols disappear. The stabilizers are now active in Cruising Mode, typically used at speeds of 3–4 knots and above. At speeds below, the system will seize operation, center and lock the fins. Operation will resume when speed is increased.



### At Anchor Mode

Ensure the stabilizer system is powered ON (H). Select the Anchor button on the control panel (I). The button switches to blue to indicate At Anchor Mode is active. This mode is active at speeds from 0–4 knots. To deactivate, select the Anchor button again.



*(NB: If both Cruising and At Anchor modes are activated, the system will automatically switch between them based on vessel speed. The system will turn OFF automatically if speed drops below 3 knots and At Anchor Mode is not enabled.)*

## Turn the System OFF

Select the ON/OFF button (H). The fins will center, become locked, and the system will be inactive. The system can also be turned ON/OFF via the PJC-2xx panel. Refer to the PJC-2xx manual for more information.



## Gain

Limits the fin acceleration. Higher is not necessarily better, but allows the user to fine-tune to current conditions.

- At Anchor Adjusts the system's response to roll while at anchor.
- Adjusts the system's response to roll while cruising.



## Disabled Fins

If a fin is disabled, this status will be displayed on the front screen. A fin can be disabled either due to an SCU (Stabilizer Control Unit) fault or because it has been manually turned off. Fins may be disabled for safety or operational reasons, including:

- To reduce forward forces.
- When at anchor and there is insufficient space to operate safely.
- When docked alongside a quay or another vessel.
- When people are swimming near the fin.

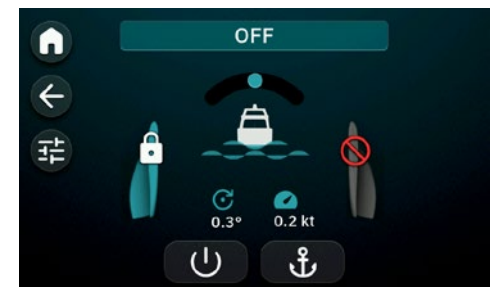

## Backing the Yacht

When any gearbox is reversing, the fins will automatically center and lock. BACKING will be indicated on the screen. After reversing, the system will either resume operation or turn off, depending on the setting of Suspend Exit State. (Backing is a WARNING state, indicated by a yellow triangle.)



## Alarms and Warnings

Alarms and Warnings are indicated in the bottom left corner of the screen.

- Alarms represent serious, immediate issues that require prompt attention or action.
- Warnings indicate potential or developing issues that should be monitored or addressed to prevent escalation. Normal operating states such as backing will appear as warnings. Entering Reduced Power Mode, High Temperature Derate, or Low Voltage Derate will also be shown as warnings.

### Viewing Warnings:

Select the yellow warning symbol to view the alarm and warning list.

The list shows current warnings, with descriptions.

*(NB: Alarms and warnings can co-exist at the same time, so always check the list carefully to understand the system's status.)*

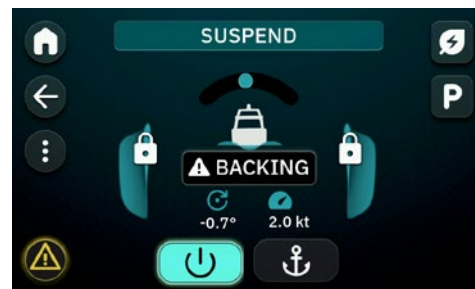

Warning	Will prevent start of system
GPS missing	Yes
Backing	No
High speed system off	No
Eco mode/reduced power	No

## Viewing Alarm

Select the red alarm symbol to view alarm list. This list shows current alarms, with descriptions. Each alarm entry provides a detailed description and a QR code for further information or troubleshooting guidance.

## Clearing Alarms

Before selecting Clear All Alarms, you must perform the necessary actions to correct the problem and ensure the issue has been resolved.

To clear alarms, select Clear All Alarms.

*(NB: For new parts required to correct the alarm issue, contact a Sleipner representative.)*

## Additional Support

Use the fault code navigator (<https://www.sleipnergrouper.com/fault-code-navigator>) to look up codes for troubleshooting guidance.





## Internet Download

*(NB: Make sure to have a stable S-Link network before proceeding to upgrade devices. If the upgrade fails due to bad communication, the device will be set in boot mode. Re-try upgrading. If the problem persists, repair S-Link communication fault before re-trying upgrade.)*

1. Enable Network connection (Wireless or Ethernet)
2. Select S-Link Devices and choose the device you wish to update Example - Upgrading SCU-12.
3. Select Upgrade on the selected device.

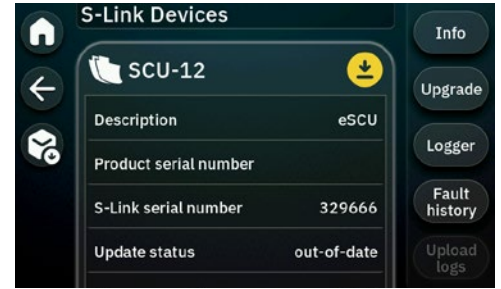

## USB Download

1. Download S-Link Programmer (<https://side-power.com/slinkupgrade/S-Link-ProgrammerSetup.zip>)
2. Start the S-Link Programmer.
  - From the menu, open Tools, Download Manager.
  - Select S-Link Offline Upgrade and download the upgrade file to a high-quality USB stick (formatted FAT32).
3. Insert the USB stick into the USB port on the back of the stabilizer panel (or use the USB extension port, if installed).
4. Follow on screen instructions.
5. You can now proceed to upgrade S-Link devices to the latest firmware version.

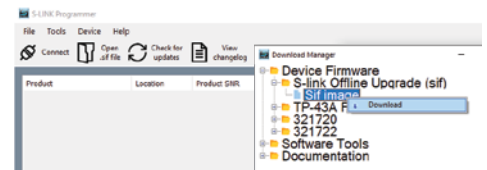

## Remote Control Function

The Remote Control feature allows authorized Sleipner technicians to remotely view and adjust stabilizer system settings to assist with troubleshooting.

### Remote Control

1. Open the Panel settings, general tab, Enter the boat name. This name will be used to identify files when uploading data to Sleipner support.
2. Enable Network connection. (Wireless or Ethernet)
3. Activate Remote Control, provide the PIN code displayed on the panel to your Sleipner technician, The technician can now initiate a remote login session.

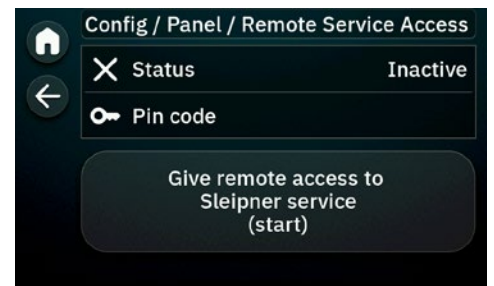

## View Fault History

1. From the Home page, select S-Link Devices.
2. Select the desired device.
3. Select Fault History.
4. Create Fault History Log.
5. The Fault History list is displayed. Select an alarm to view more details.
6. The fault history can be uploaded when an active internet connection is established.

## Additional Support

Use the fault code navigator (<https://www.sleipnergroun.com/fault-code-navigator>) to look up codes for troubleshooting guidance.

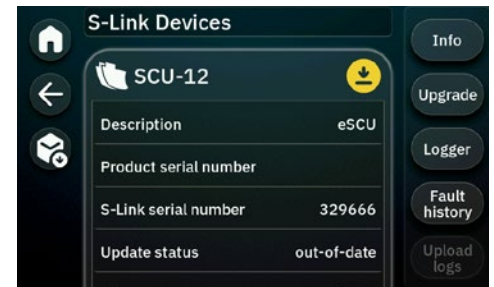

Some devices allow data logging. This should only be performed when: Specifically requested by Sleipner, or triggered remotely by Sleipner personnel.

## Logging

1. To begin logging: Press the Log button on the selected device page.
2. Choose the logging mode according to instructions from Sleipner.
3. With an internet connection enabled: Press Upload Logs to send the data to the Sleipner server. Notify your Sleipner contact once the upload is complete.

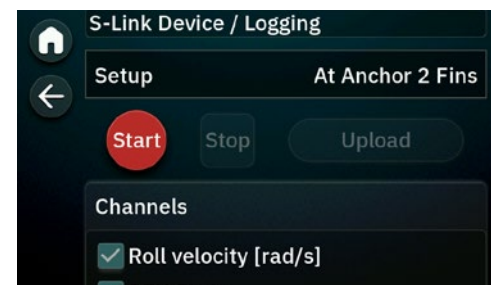

Scan the QR code below to access Sleipner's Fault Code Navigator.

Fault codes can be entered in the Fault Code Navigator to receive fault description and guidance on resolving the issue.

A complete list of fault codes and troubleshooting tips can also be downloaded.



[www.sleipnergrouper.com/support/fault-code-navigator](http://www.sleipnergrouper.com/support/fault-code-navigator)

## FIN ACTUATOR UNITS

The stabilizer system is in general a low maintenance product, but as all moving parts some degree of preventive maintenance will increase the lifetime and reliability of the system.

A chart for recommended check and service points is thereby offered at the end of this section.

For all new installations, or after a major parts change, a basic check should be done after the first 100 hours of operation or after the first week of proper use:

- Check that all hydraulic fittings are tight.
- Check all hoses for chaffing, and ensure they are not in contact with any moving parts.
- Inspect hydraulic cylinder rods and gland seals for damage, leaking, or scratches.
- Inspect the dirt indicator on the return oil filter.
- “Shake” the fins from the outside to feel if there is any play in any connection.
- Open the fins manual decouple valve (at the actuator point of allow movement) and manually move the fin fully to both sides to feel that there is not specific tough spot in the bearings.

Every time the boat is out of the water for service or other reason, we recommend that you take this opportunity to more thoroughly check some points that is not possible when the boat is in the water. A proper cleaning and check of the fins anodes (if fitted, can also be bonded to boats large anode system) is also appropriate during a haul out.

- Axial and radial play in the shaft can also be checked at this time; see the table below that details play allowances. A dial indicator is recommended for this procedure.
  - o Radial play should be checked with the indicator/micrometer positioned just below the seal housing between the top of the fin and the underside of the hull.
  - o Axial play should be checked by measuring the relative distance between the top of the axle shaft and hull plate. By using a crow bar on the twin yoke, moving and feeling the tightness of the bearings inside the boat while measuring from a fixed point with a micrometer.

	Shaft Radial Play (mm)	Shaft Axial Play (mm)
	Maximum	Maximum
<b>SPS 65/66/67</b>	0.10	0.20
<b>SPS 55/90/91/92/93/94/96/97</b>	0.15	0.30

***(NB: Because of the big variation in different vessels actual use and operation, system specifications and maintenance, it is not possible to accurately predict the anticipated service life of the main shaft bearings. Thereby, Sleipner recommends general inspection and corrective actions if required. and that the bearing clearances be checked periodically when possible so to avoid extra hallout between normal service need.)***

The service timing indicated in the chart is based calculations and experience, but please note that because of the variations in use and load, both due to different operation and for example different fin sizes allowed on the same actuator size, the life of bearings and seals can be both longer and shorter than indicated by the maintenance chart.

## FINS

It is recommended that a thorough inspection of the fins be performed when the vessel is lifted out of water for maintenance. Damages on the fin surface must be repaired with vinylester/epoxy done by professionals

## HYDRAULICS

The pressure filters require periodic element changes as per the maintenance schedule. The valves and manifolds are to be inspected regularly for external damage. To avoid corrosion and deterioration, a water inhibitor such as WD-40 or similar should be applied to the valves and fittings immediately after wash-down of the equipment. ***(NB: Refer to your hydraulic installation manual for more information.)***

### \*Filter replacement:

We recommend to replace pressure and return line filter elements after the initial start up and test period, and latest at 50 operating hours. Thereafter every 2000 operating hours or every 2nd year.

Both pressure filter and return filter have pressure drop indicators. Check indicators every 6th month. The check have to be done with oil temperature above 40 °C, and the most flow demanding consumer active. Filter element replacement are required if indicators are in the red area.

### Hydraulic oil replacement:

Every 4000 operating hours or every 3rd year. For heavy duty applications and commercial use, we recommend oil sample analyses every year. \*\*\*Check oil colour every 6th month. White or grey oil indicates water ingress or heavy condensation. This will require filter replacement, oil replacement and flushing of the system. See schedule and Hydraulic system manual.

### CONTROL SYSTEM

With the exception of keeping the electrical parts and wiring clean, dry and damage-free, no maintenance is required for these parts. In general, all electrical equipment should be periodically checked to ensure that there are no mechanical damage or water build-up.

### POWER UNIT

The power unit and its associated components require maintenance and have a lifetime so will in the future require replacement which can be done preventively as indicated within the charts here, to avoid potential follow damage to other parts.

The hydraulic oil integrity must be checked as per the schedule by extracting a sample from the system for analysis to ensure it is within the standards of its specifications.

The hydraulic power unit motor should not stay unused for longer periods, and either manually rotated every 3 months or started to ensure proper lubrication of the shafts and bearings on its shaft and bearings.

### PREVENTATIVE MAINTENANCE SCHEDULE

The maintenance schedules in this section indicate the recommended preventative maintenance intervals for equipment supplied by Sleipner. Components utilized in Sleipner Stabilizer Systems but not supplied by Sleipner are not included in the maintenance schedule or under any Sleipner warranty.

The maintenance intervals are listed in hours of operation and time where relevant. Maintenance is to be performed according to this schedule utilizing time or hour intervals, whichever comes first. . The maintenance schedule incorporates the minimum required maintenance to ensure correct operation of the system. Should these guidelines not be followed, the warranty for those items will be void.

To perform maintenance, replacement parts may need to be purchased. Refer to the recommended spares list and/or drawings for associated part numbers.

### Cooling System

cooling system. Must be flushed with fresh water and emptied if boat is left unused more than 2 weeks. Cooler maintenance: consult Bowman manual.

 Contact a Authorized Sleipner technician.

\* If analysis of the scheduled oil sample indicates an elevated level of brass particles in the hydraulic system, the pumps should be replaced or overhauled as soon as possible. Delay in component removal and system flushing will lead to contamination problems throughout the hydraulic system. Erratic component operation may be a symptom of hydraulic fluid contamination.







\*\*\* 2000 operating hours or annually, whichever occurs first.

\*\*\*\* Fins should be inspected annually by diver if possible

The data in the table below is provided to assist the vessel in scheduling the appropriate service staff and coordination of vessel docking (haul out) for maintenance procedures.

Level	Description
1	Onboard maintenance possible at sea No shore support required
2	Shore supported maintenance and corrective measures
3	Trained personnel required - Sleipner personnel or equivalent
D	Dry - Vessel must be out of water to perform task
W	Wet - Vessel can be in water to perform task

## A. HULL UNIT

Maintenance schedule	Service level	250h	500h	2000h	4000h	8000h	12000h	When out of water	When required	Months/Year
1. Change oil in bearing assembly 	1 D				✓					36/3 <sup>rd</sup>
2. Inspect spherical bearings, and Main Cylinders for external leakage	1 W			✓						
3. Inspect Stabilizer Manifolds	1 W			✓						
4. Inspect Stabilizer Manifolds Electrical Connections	1 W			✓						
5. Inspect Fin Angle Sensor Belts	1 W			✓						
6. Inspect Twin Yoke Area	1 W			✓						
7. Inspect Hydraulic Hoses	1 W			✓						
8. Check Shaft Clearances 	3 D							✓		
9. Replace Lower Shaft Seals 	3 D								✓	
10. Replace Main Shaft Bearings 	3 D								✓	
11. Inspect and replace Spherical Bearings and Cylinder Pins if necessary. (NOT relevant for SPS55) 	2 W				✓				✓	
12. Rebuild/Replace Cylinders 	3 W				✓				✓	
13. Replace the Fin Angle Belt	1 W				✓				✓	
14. Replace hydraulic actuator hoses	3 W				✓				✓	36/3 <sup>rd</sup>
15. Add pint for SPS55 actuator	1 W		✓							
16. Check and grease racks	1 W		✓							

## B. FINS

Maintenance schedule	Service level	250h	500h	2000h	4000h	8000h	12000h	When out of water	When required
1. Inspect Fin Surfaces	1 D ****			✓****				✓	

## B. HYDRAULIC POWER UNIT

Maintenance schedule	Service level	250h	500h	2000h	4000h	8000h	12000h	When out of water	When required	Months/Year
1. Inspect the Dirt Indicator of the return filter, replace when required	1 W		✓							6/0.5
2. Inspect Flexible Hoses	1 W		✓							
3. Inspect Suction Hoses	1 W		✓							
4. Inspect Electrical Connections	1 W			✓						
5. Inspect Cooling Pump	1 W		✓							
6. Inspect Oil Cooler Tubes	1 W						✓			
7. Inspect Pump Drive Coupling	1 W				✓					
8. Inspect Motor and Frame Mounts	1 W			✓						
9. Test Hydraulic Oil Quality by means of taking sample***	2 W			✓					✓	12/1 <sup>st</sup>
10. Replace Return Filter Element*	1 W			✓					✓	24/2 <sup>nd</sup>
11. Replace Pressure Filter Element*	1 W			✓					✓	24/2 <sup>nd</sup>
12. Change Oil. Refill with mineral based hydraulic oil ISO 11158 HV, VG46	1 W				✓				✓	36/3 <sup>rd</sup>
13. Replace Drive Coupling Element	3 W					✓				
14. Rebuild/Replace Cooling Pump	3 W								✓	
15. Replace Hydraulic Hoses	3 W								✓	
16. Replace Oil Cooler	3 W								✓	
17. Replace Hydraulic Pumps*	3 W								✓	

## B. CONTROL SYSTEM

Maintenance schedule	Service level	250h	500h	2000h	4000h	8000h	12000h	When out of water	When required
1. Clean the Cooling Fan of the VFD ①	1/3 W			✓					

Follow the VFD manual instructions



**Find your local professional dealer from our certified worldwide network for expert service and support. visit our website [www.sleipnergroun.com/support](http://www.sleipnergroun.com/support)**

## Spare Parts and Additional Resources

---

**For additional supporting documentation, we advise you to visit our website [www.sleipnergroun.com](http://www.sleipnergroun.com) and find your Sleipner product.**

## Patents

---

At Sleipner we continually reinvest to develop and offer the latest technology in marine advancements. To see the many unique designs we have patented, visit our website [www.sleipnergroun.com/patents](http://www.sleipnergroun.com/patents)

1. Sleipner Motor AS (The “Warrantor”) warrants that the equipment (parts, materials, and embedded software of products) manufactured by the Warrantor is free from defects in workmanship and materials for purpose for which the equipment is intended and under normal use and maintenance service (the “Warranty”).
2. This Warranty is in effect for two years (Leisure Use) or one year (Commercial and other Non-leisure Use) from the date of delivery/purchase by the end user, with the following exceptions:
  - (a) For demonstration vessels, or vessels kept on the water, the dealer is considered as the end user from 6 months after their launch of the vessel;
  - (b) The warranty period starts no later than 18 months after the first launch of the vessel.Please note that the boat manufacturer and dealer must pay particular attention to correct maintenance and service both by the products manuals as well as general good practice for the location the boat is kept in the period the boat is in their care. In cases where the 6 and 18 months grace periods for boat builders and dealers are passed, it is possible to obtain a full warranty upon inspection and approval of the warrantor or such representative.
3. Certain parts, classified as wearable or service parts, are not covered by the warranty. A failure to follow the required maintenance and service work as described in the product manual render all warranty on parts or components directly or indirectly affected by this void. Please also note that for some parts, time is also a factor separately from actual operational hours.
4. This Warranty is transferable and covers the equipment for the specified warranty period.
5. The warranty does not apply to defects or damages caused by faulty installation or hook-up, abuse or misuse of the equipment including exposure to excessive heat, salt or fresh water spray, or water immersion except for equipment specifically designed as waterproof.
6. In case the equipment seems to be defective, the warranty holder (the “Claimant”) must do the following to make a claim:
  - (a) Contact the dealer or service centre where the equipment was purchased and make the claim. Alternatively, the Claimant can make the claim to a dealer or service centre found at [www.sleipnergroupp.com](http://www.sleipnergroupp.com). The Claimant must present a detailed written statement of the nature and circumstances of the defect, to the best of the Claimant’s knowledge, including product identification and serial nbr., the date and place of purchase and the name and address of the installer. Proof of purchase date should be included with the claim, to verify that the warranty period has not expired;
  - (b) Make the equipment available for troubleshooting and repair, with direct and workable access, including dismantling of furnishings or similar, if any, either at the premises of the Warrantor or an authorised service representative approved by the Warrantor. Equipment can only be returned to the Warrantor or an authorised service representative for repair following a pre-approval by the Warrantor’s Help Desk and if so, with the Return Authorisation Number visible postage/shipping prepaid and at the expense of the Claimant.
7. Examination and handling of the warranty claim:
  - (a) If upon the Warrantor’s or authorised service Representative’s examination, the defect is determined to result from defective material or workmanship in the warranty period, the equipment will be repaired or replaced at the Warrantor’s option without charge, and returned to the Purchaser at the Warrantor’s expense. If, on the other hand, the claim is determined to result from circumstances such as described in section 4 above or a result of wear and tear exceeding that for which the equipment is intended (e.g. commercial use of equipment intended for leisure use), the costs for the troubleshooting and repair shall be borne by the Claimant;
  - (b) No refund of the purchase price will be granted to the Claimant, unless the Warrantor is unable to remedy the defect after having a reasonable number of opportunities to do so. In the event that attempts to remedy the defect have failed, the Claimant may claim a refund of the purchase price, provided that the Claimant submits a statement in writing from a professional boating equipment supplier that the installation instructions of the Installation and Operation Manual have been complied with and that the defect remains.
8. Warranty service shall be performed only by the Warrantor, or an authorised service representative, and any attempt to remedy the defect by anyone else shall render this warranty void.
9. No other warranty is given beyond those described above, implied or otherwise, including any implied warranty of merchantability, fitness for a particular purpose other than the purpose for which the equipment is intended, and any other obligations on the part of the Warrantor or its employees and representatives.
10. There shall be no responsibility or liability whatsoever on the part of the Warrantor or its employees and representatives based on this Warranty for injury to any person or persons, or damage to property, loss of income or profit, or any other incidental, consequential or resulting damage or cost claimed to have been incurred through the use or sale of the equipment, including any possible failure or malfunction of the equipment or damages arising from collision with other vessels or objects.
11. This warranty gives you specific legal rights, and you may also have other rights which vary from country to country.

## Introduction:

At Sleipner Group, we prioritize sustainability and encourage the repair and re-manufacturing of products to extend their life cycles. If disposal is necessary, please follow these guidelines to recycle and manage waste responsibly, ensuring our efforts align with environmental protection efforts.

## Electric Motors and Electronics:

- Disconnect from any power sources and dismantle them carefully.
- Recycle components through certified e-waste recycling centers that can adequately handle and recover electronic materials.
- Dispose of any non-recyclable electronic parts according to local environmental regulations.

## Metals:

- Collect and sort metal parts for recycling as scrap metal.
- To increase recycling efficiency, ensure that metals are clean and free from non-metal attachments.

## Plastics:

- Identify recyclable plastics based on local recycling guidelines.
- Remove any non-plastic components and clean them before recycling to improve the quality of the recycled material.

## Hazardous Materials:

- Correctly identify any hazardous substances within components, such as batteries or capacitors etc.
- Follow local regulations for the safe disposal of hazardous materials to prevent pollution and protect environmental health.

## General Disposal Instructions:

- Consult local recycling programs to determine the acceptability of various materials.
- Use authorized disposal services to ensure compliance with environmental standards.

## Safe Disposal Practices:

- Adhere to local laws and regulations for waste management to minimize environmental impact and ensure community safety.

This guide is designed to help reduce our products' environmental footprint through responsible end-of-life management. Please contact your local waste management supplier or our support team for more specific disposal information or further assistance.



# SLEIPNER

*Ocean born. Tech bred.*

**SLEIPNER MOTOR AS**

P.O. Box 519

N-1612 Fredrikstad

Norway

[www.sleipnergroup.com](http://www.sleipnergroup.com)

Made in Norway

© Sleipner Motor AS, All rights reserved

The information given in the document was right at the time it was published. However, Sleipner Motor AS cannot accept liability for any inaccuracies or omissions it may contain. Continuous product improvement may change the product specifications without notice. Therefore, Sleipner Motor AS cannot accept liability for any possible differences between product and document. Learn more about our products at [www.sleipnergroup.com](http://www.sleipnergroup.com)