

# SPARTAN AIR

SPARTAN SERIES | Air Heater



  
**WALLAS REMOTE APP  
IS AN EASY TO USE  
ALTERNATIVE HEATER  
CONTROL**



The Greenboost burner burns renewable fossil-free diesel cleanly and energy-efficiently, as well as fossil based diesel fuels.

Three inlets and outlets allow greater installation flexibility and drying performance.

Fully enclosed laminar burning process ensures a quiet sound level and wind resistant burn.



Variable output eliminates system cycling and reduces noise, keeping you comfortable.

Brushless blower motors have a very long life-cycle supporting reliably long service intervals.

Drawing fuel directly from the main tank of the vessel saves space and eliminates the need for a separate tank.



Turn the heater on remotely with the Wallas App and enjoy a warm boat upon arrival.

Adjust temperature from anywhere on board with your Wallas phone app to keep your crew happy.

Wireless sensor monitors cabin temperature with improved accuracy and flexibility.

## SPECIFICATIONS

|                          |                                 |
|--------------------------|---------------------------------|
| Fuel:                    | Diesel                          |
| Power:                   | 1400-4500 W (4,700-15,300 BTU)  |
| Operating voltage:       | 12 V                            |
| Fuel consumption:        | 0,16-0,46 l/h (5,4-15,5 oz/hr)  |
| Electricity consumption: | 0.7-4.5 A                       |
| Air volume at min heat:  | 102 m <sup>3</sup> /h (60 cfm)  |
| Air volume at max heat:  | 226 m <sup>3</sup> /h (133 cfm) |

## RECOMMENDED BUILDS

|                            |                   |
|----------------------------|-------------------|
| Boats:                     | 9-12 m (29-40 ft) |
| Camper Vans: (retrofitted) | Large motorhomes  |
| Trailers:                  | 6 m (20 ft)       |

## MATERIALS

Stainless steel, high-grade aluminum, other corrosion-resistant materials

## ADVANCED CONTROL PANEL

Use heater in Thermostatic Mode to hold a target room temperature

Maximize the air volume with Air Boost for quick defrosting or drying

Switch to Manual Mode and deliver heat at six power levels

Blow fresh air with Ventilation Mode when heating is not needed

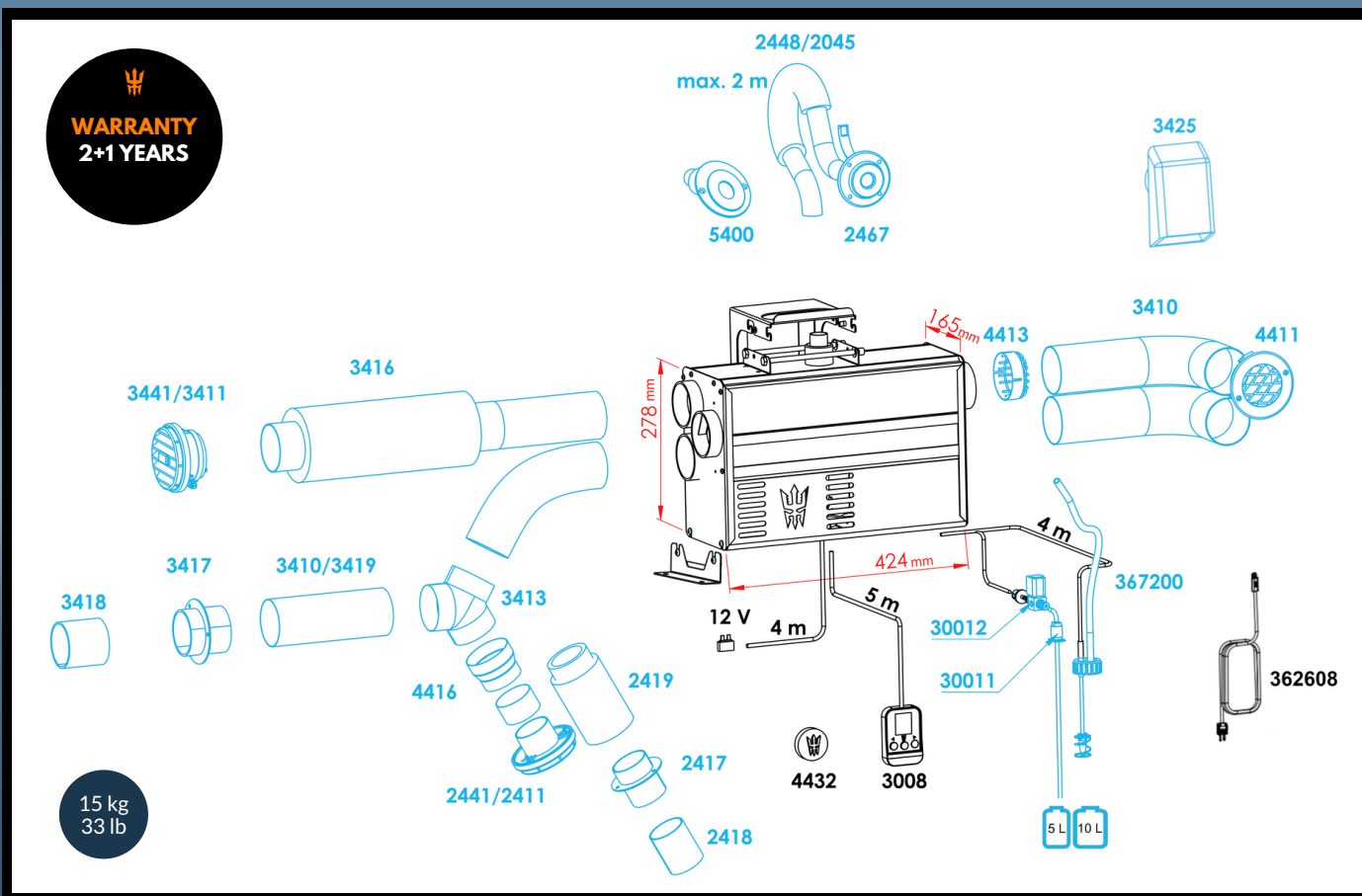

Accessories in black come with the standard package. Accessories in blue are additional. The calculated values are measured in a reference measurement wall, which is constructed to respond to a typical boat installation. The technical values have been measured with the maximum length of ducting, exhaust pipe, fuel line, and power cord. The figures allow for 10% reserve - yours may vary.

All rights reserved. Wallas-Marine reserves the right to change or improve its products and to make changes in the content of this product material without obligation to notify any person or organization of such changes or improvements. Go to [www.wallas.com](http://www.wallas.com) for current updates and supplemental information concerning this product.

